

SECTION A-A

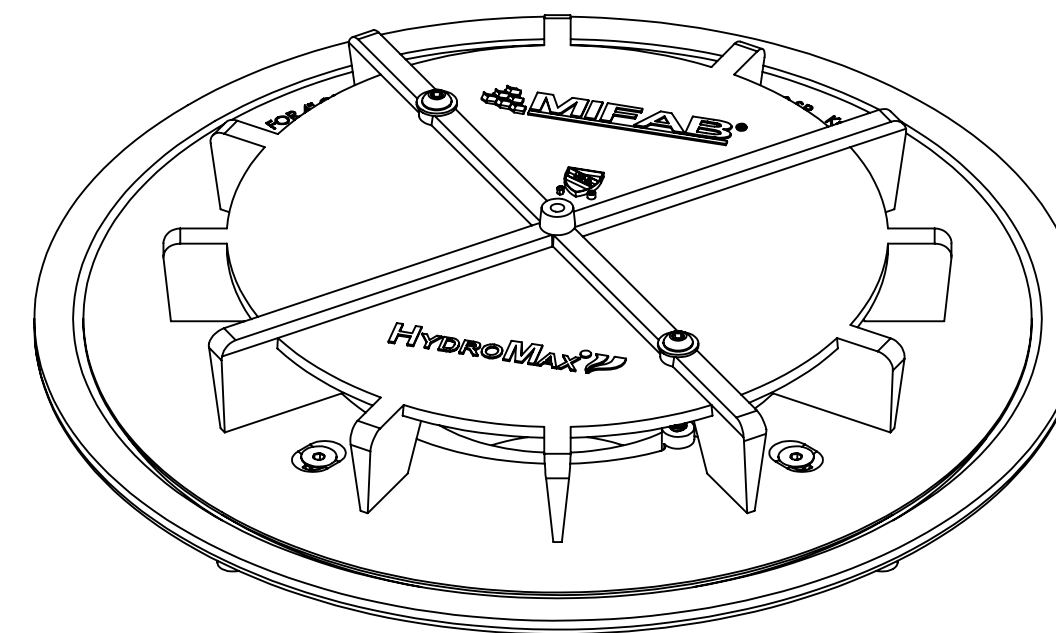
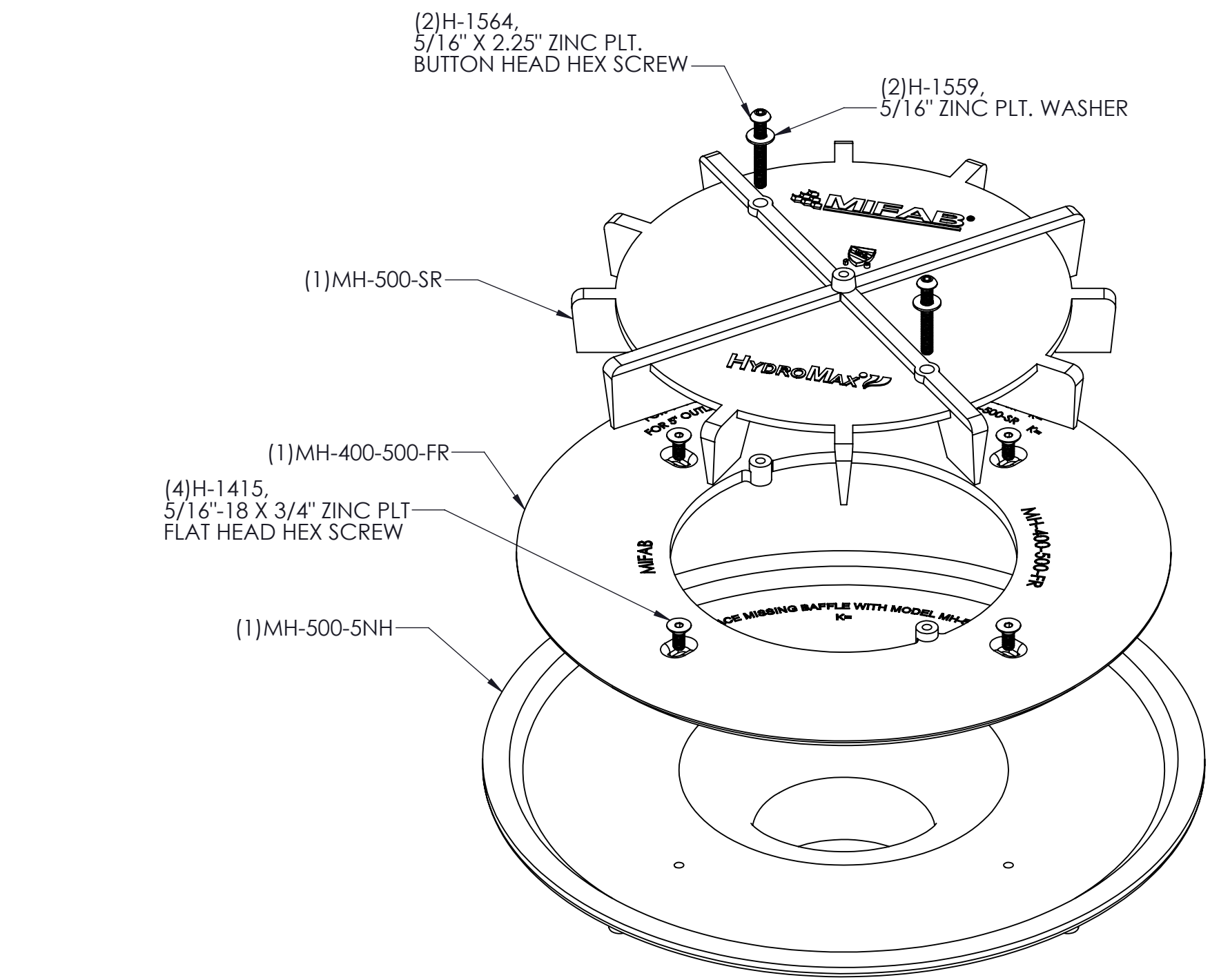
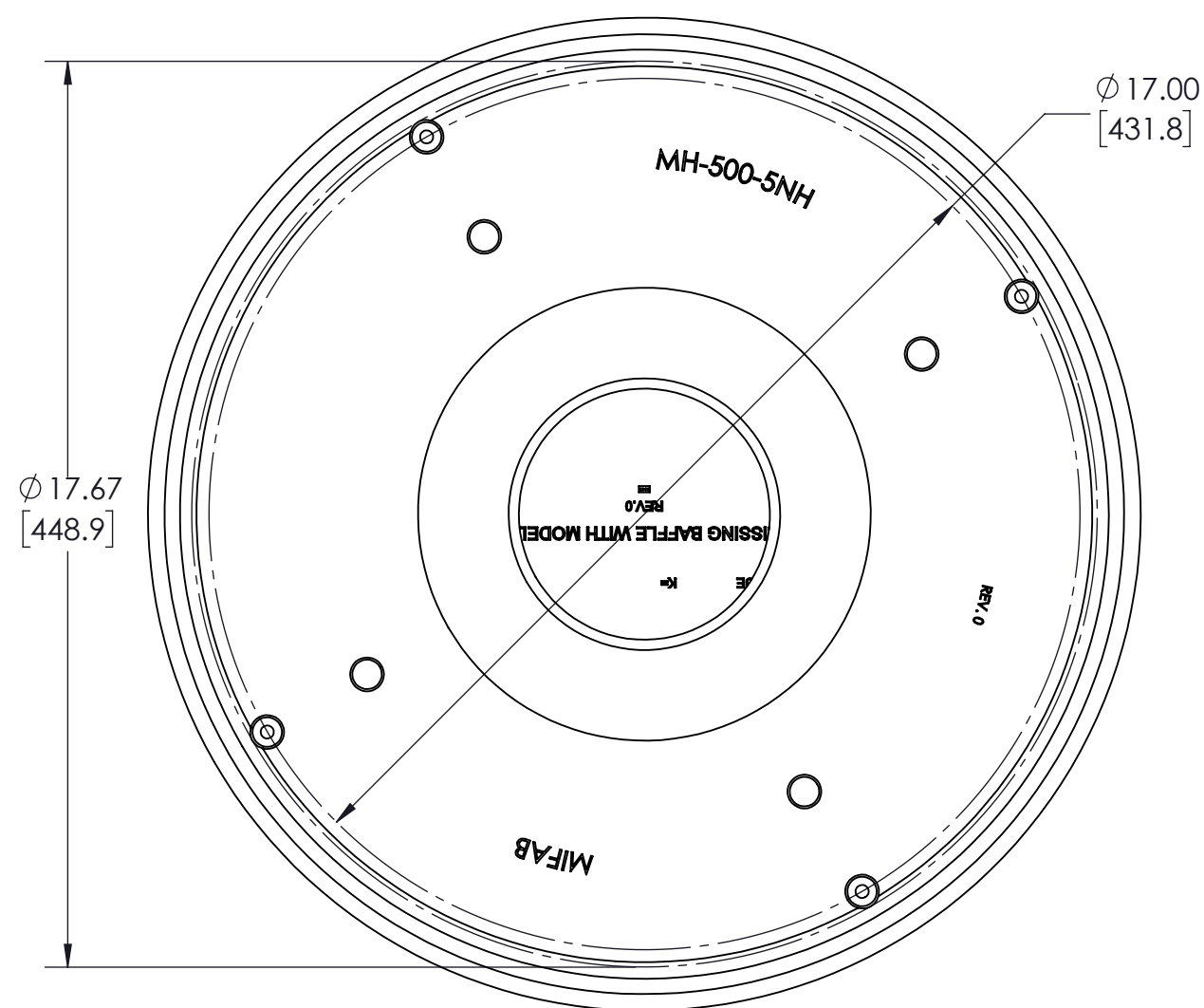

PROPRIETARY AND CONFIDENTIAL
 THE INFORMATION CONTAINED IN THIS DRAWING IS THE SOLE PROPERTY OF MIFAB, INC. ANY REPRODUCTION IN PART OR AS A WHOLE WITHOUT THE WRITTEN PERMISSION OF MIFAB, INC. IS PROHIBITED.

LASER/SHEAR:	UNLESS OTHERWISE SPECIFIED: DIMENSIONS ARE IN INCHES	NAME	DATE
BRAKE PRESS:	TOLERANCES: FRACTIONAL ±1/16	DRAWN	KT 09/24/15
WELDED BY:	ANGULAR: MACH ±1° BEND ±1°	CHECKED	
CLEAN/PAINT:	TWO PLACE DECIMAL ±.015	ENG APPR.	
COMPLETED BY:	THREE PLACE DECIMAL ±.010	MFG APPR.	
REVIEWED BY:	TYPICAL DRAFT ANGLE 2°	Q.A.	
NEXT ASSY	MATERIAL DESCRIPTION 56 LB	QUANTITY:	
USED ON	FINISH PART#		
APPLICATION	DO NOT SCALE DRAWING		

MIFAB
HydroMax
 Leaders in Siphonic Drainage

TITLE: 5" SIPHONIC DRAIN

SIZE	DWG. NO.	REV
C	MH-500	

SCALE: 9:32 WEIGHT: 56 LB SHEET 1 OF 1