

8

7

6

5

4

3

2

1

F

E

D

C

B

A

F

E

D

C

B

A

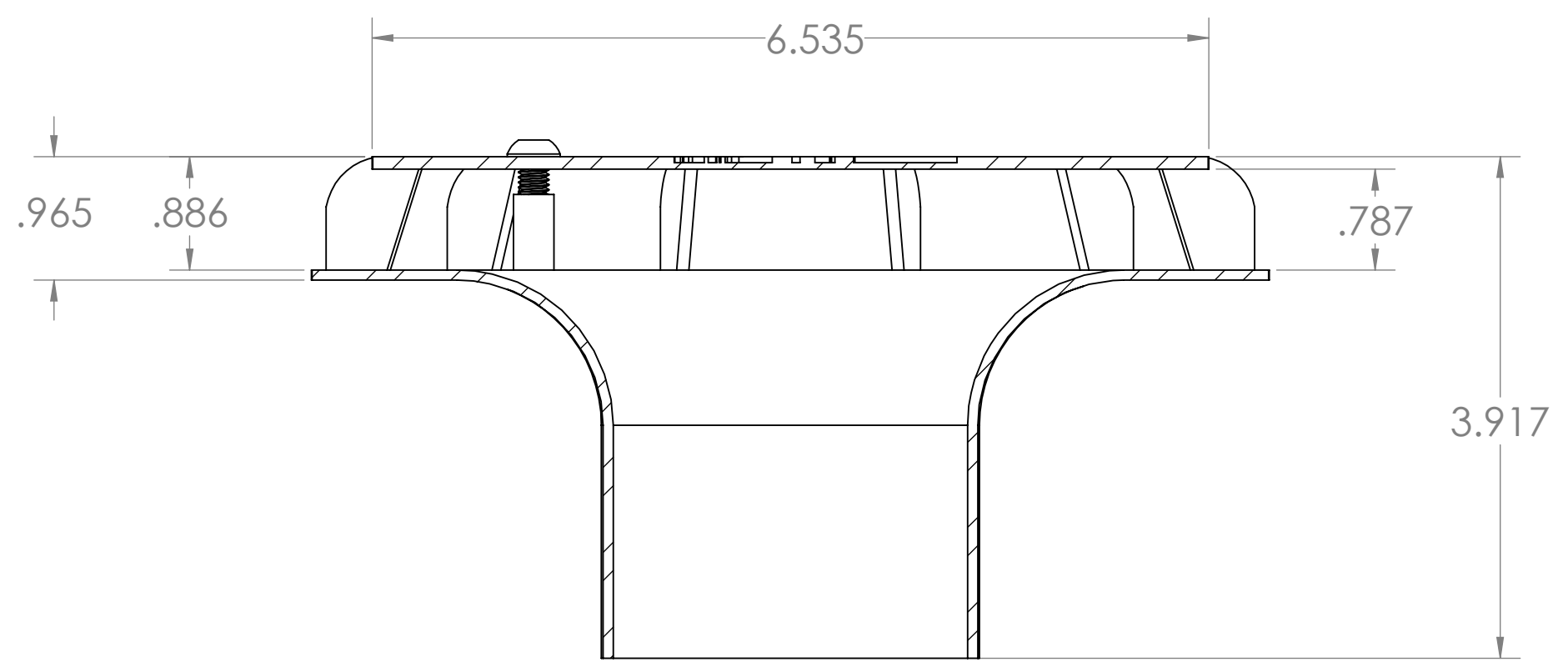
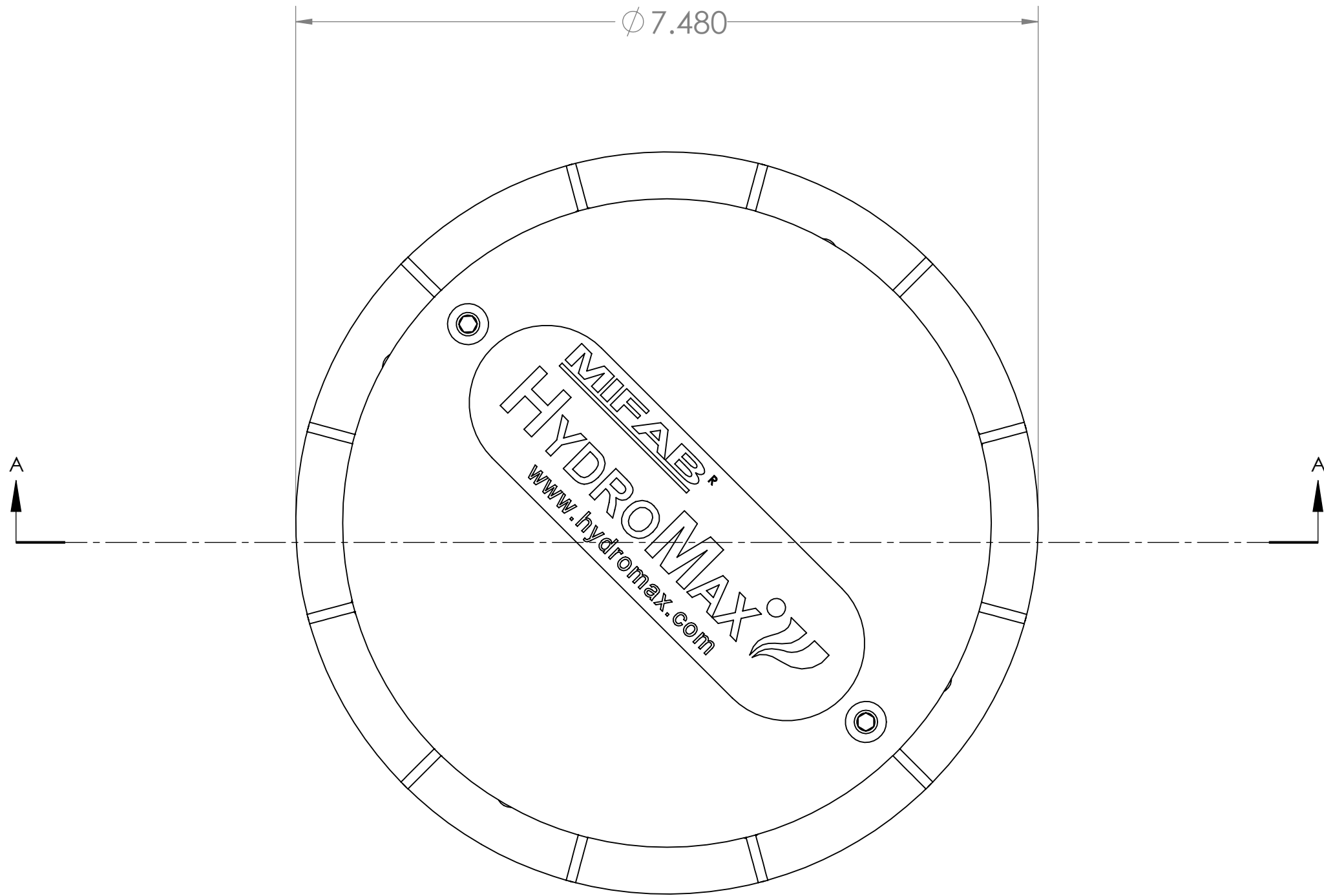

SECTION A-A  
SCALE 1 : 1.25

**PROPRIETARY AND CONFIDENTIAL**  
THE INFORMATION CONTAINED IN THIS DRAWING IS THE SOLE PROPERTY OF MIFAB, INC. ANY REPRODUCTION IN PART OR AS A WHOLE WITHOUT THE WRITTEN PERMISSION OF MIFAB, INC. IS PROHIBITED.

LASER/SHEAR:		UNLESS OTHERWISE SPECIFIED:		NAME	DATE
BRAKE PRESS:		DIMENSIONS ARE IN INCHES		DRAWN	XX
WELDED BY:		TOLERANCES:		CHECKED	XX
CLEAN/PAINT:		FRACTIONAL ±1/16		ENG APPR.	
COMPLETED BY:		ANGULAR: MACH ±1° BEND ±1°		MFG APPR.	
REVIEWED BY:		TWO PLACE DECIMAL ±.015		Q.A.	
NEXT ASSY	USED ON	THREE PLACE DECIMAL ±.010		QUANTITY:	
APPLICATION		TYPICAL DRAFT ANGLE 2°			
		MATERIAL DISCRPTION	XX		
		FINISH PART#	XX		



TITLE: XX

SIZE DWG. NO. REV  
**C** MH-305-G

SCALE: 1:2 WEIGHT: SHEET 1 OF 1