

- GENERAL NOTES :
1. Initial vertical drop under drain is from top of the roof membrane to the center of elbow.
 2. All other dimensions are center to center.
 3. Tolerance is limited to pipe length :
+/- 4" for pipe ≤ 4'Ø
+/- 8" for pipe > 4'Ø
 4. Any changes beyond tolerance and on configuraion should be recalculated.

PIPE MATERIAL :
DESIGN RAINFALL RATE :
REVISION DATE :

1 Lower Level 2 Drain System
Scale: 1/4" = 1'-0"

SHW HQ

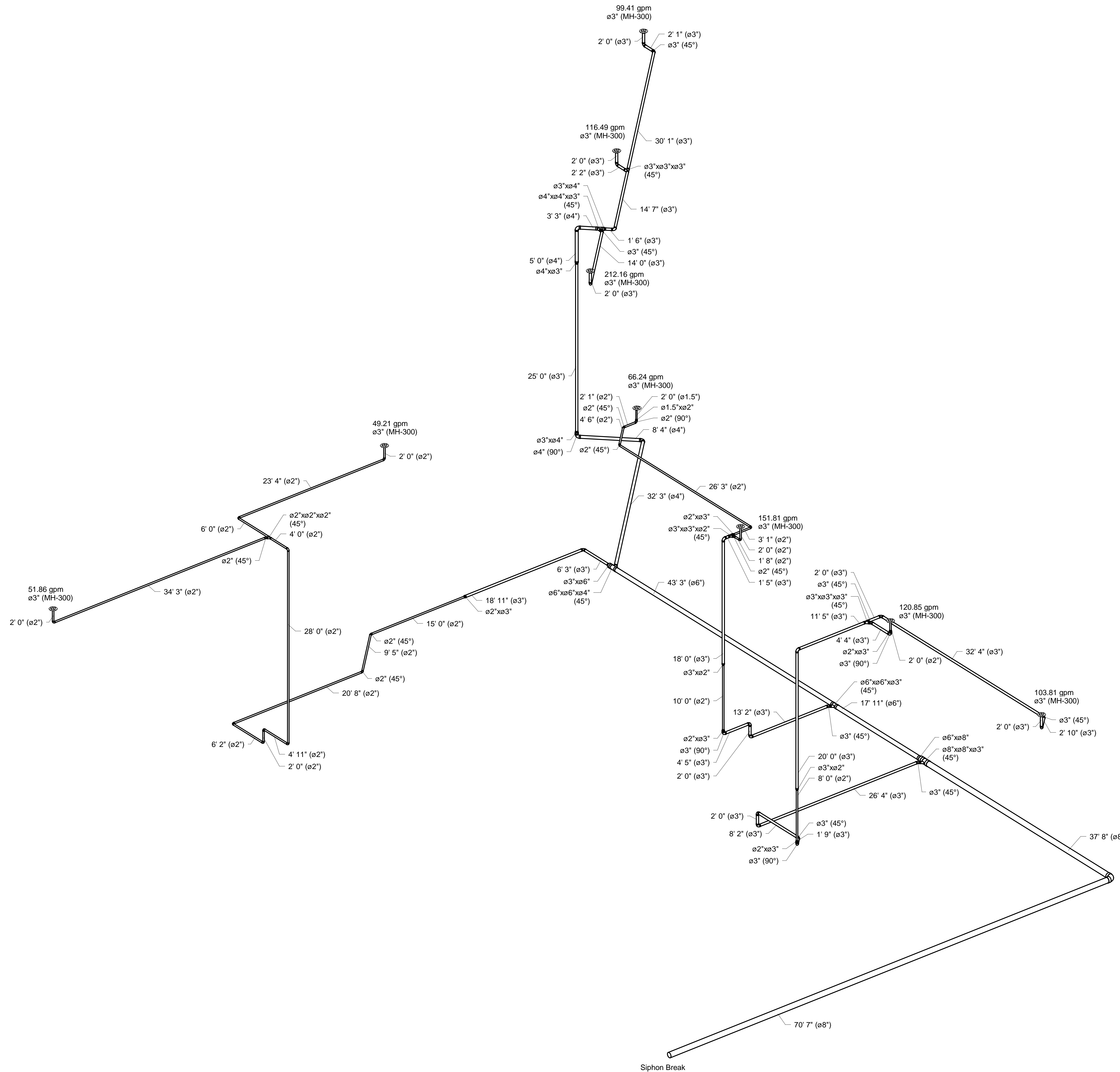

- GENERAL NOTES :
1. Initial vertical drop under drain is from top of the roof membrane to the center of elbow.
 2. All other dimensions are center to center.
 3. Tolerance is limited to pipe length :
 +/- 4" for pipe ≤ 4"Ø
 +/- 8" for pipe > 4"Ø
 4. Any changes beyond tolerance and on configuraion should be recalculated.

PIPE MATERIAL : PVC sch 40 solid
 DESIGN RAINFALL RATE :
 REVISION DATE :

UIF

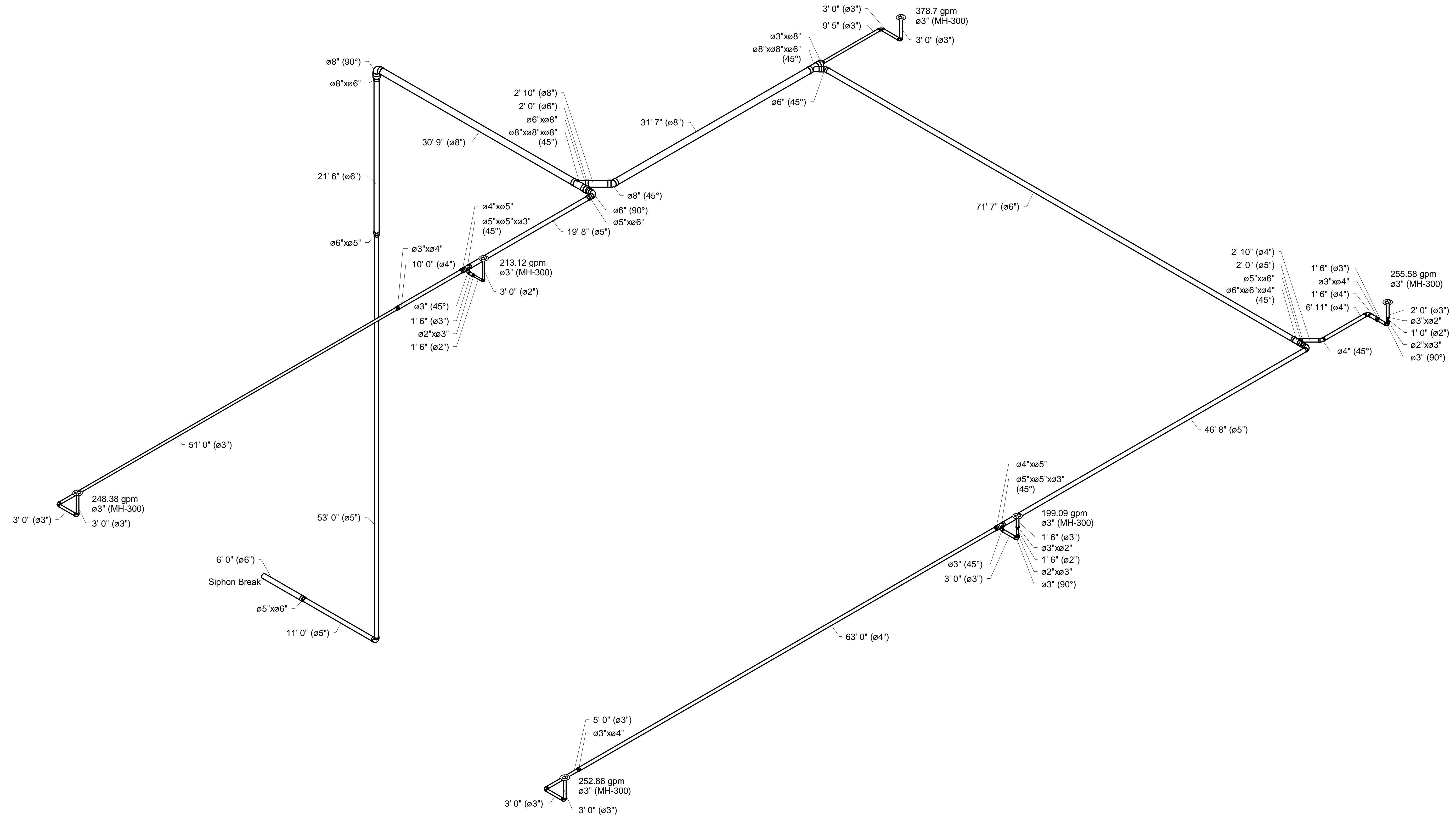

- GENERAL NOTES :
- Initial vertical drop under drain is from top of the roof membrane to the center of elbow.
 - All other dimensions are center to center.
 - Tolerance is limited to pipe length :
 +/- 4" for pipe ≤ 4'Ø
 +/- 8" for pipe > 4'Ø
 - Any changes beyond tolerance and on configuraion should be recalculated.

PIPE MATERIAL :
 DESIGN RAINFALL RATE :
 REVISION DATE :

1 RD 08-15-22 KG
 Scale: 3/16" = 1'-0"

MIDTOWN - MHK

ASPE 45:

- 9.9.1 When a siphonic roof drainage system is connected to an underground storm sewer system, the siphonic action shall be broken before the system is connected to the main storm sewer system.
- 9.9.2 Siphonic roof drainage system should tie into a vented manhole or sump structure with free area of at least twice the cross-sectional area of the siphonic discharge pipe. This may be accomplished by substituting a standard manhole cover with a catch basin grate. Where a catch basin grate or other vented cover is not possible (e.g., the manhole is inside a building and be sealed tight against possible overflow), a vent pipe of a minimum diameter equivalent to the siphonic discharge pipe may be extended from the manhole structure and terminate in an area approved by the governing plumbing code.

Breaking a siphonic system requires 2 actions:

1. Increase pipe diameter back to gravity flow following local sizing requirements.
2. Reintroduce atmosphere back into the system.

Free Area Requirement for Each Pipe Diameter

Pipe Diameter	Radius(r)	Free Area(2πr ²)
1.5"	0.75"	3.54 sq in
2"	1"	6.294 sq in
3"	1.5"	14.162 sq in
4"	2"	25.176 sq in
6"	3"	56.646 sq in
8"	4"	100.704 sq in
10"	5"	157.35 sq in
12"	6"	226.584 sq in
14"	7"	308.406 sq in
16"	8"	402.816 sq in
18"	9"	509.814 sq in
20"	10"	629.4 sq in

EX: (2) 4" siphonic pipes NOT assuming 4"+4" = 8"
25sq in + 25sq in = 50sq in which would be oversized.

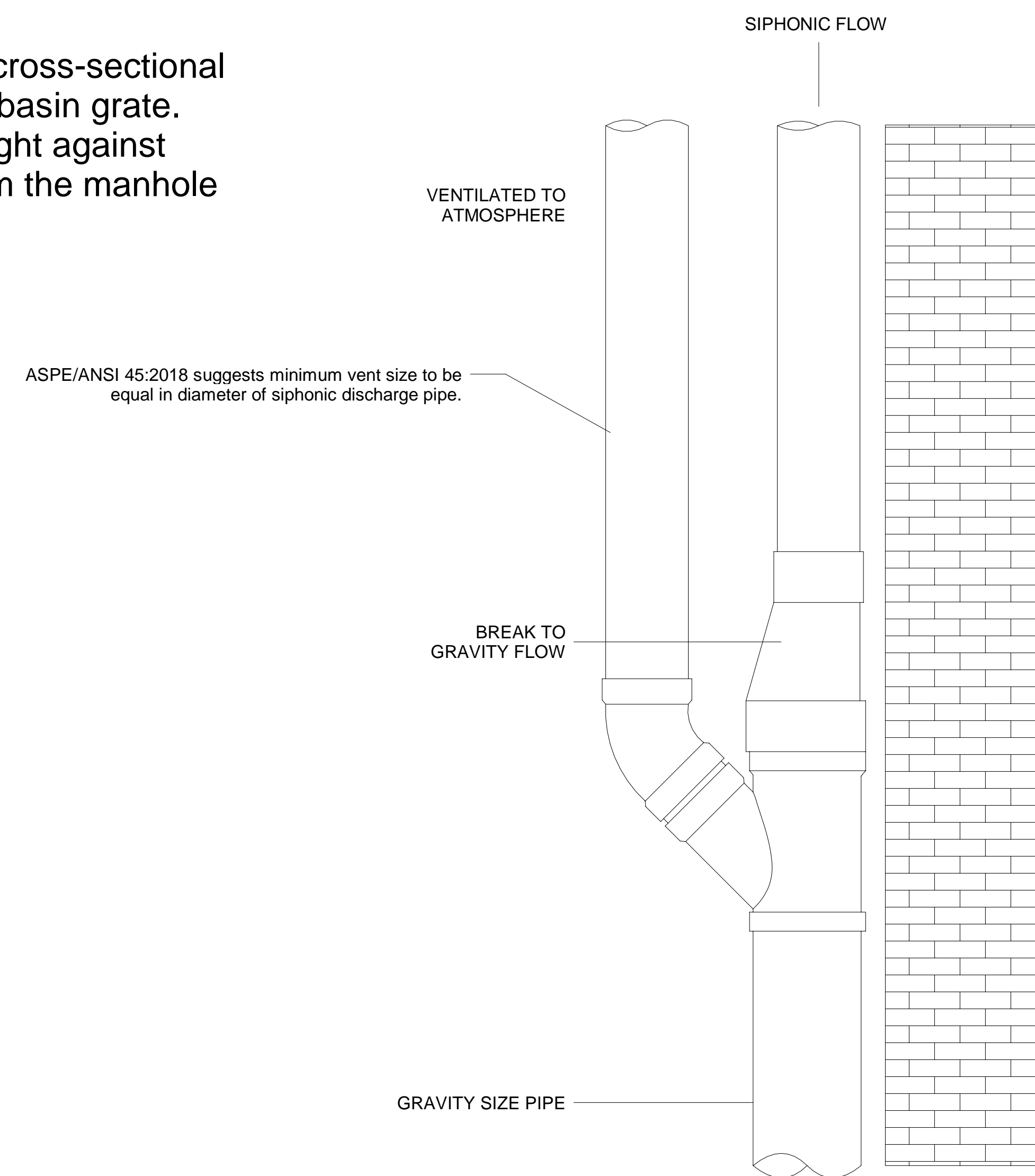

2 SIPHON BREAK IN VERTICAL
Scale: NTS

Grate Shape	1-Pipe Only Siphonic Discharge Diameter	Vent Part Number	Free Area	Drain Body A Dim	Grate B Dim
Round	>6"	MIFAB HydroMax MH-F1340	68in ²	15"	13"
Round	>8"	MIFAB HydroMax MH-F1360	105in ²	15"	16"
Square	>6"	MIFAB HydroMax MH-F1460	75in ²	19"	16"
Square	8" - 12"	MIFAB HydroMax MH-F1580	200in ²	27"	24"

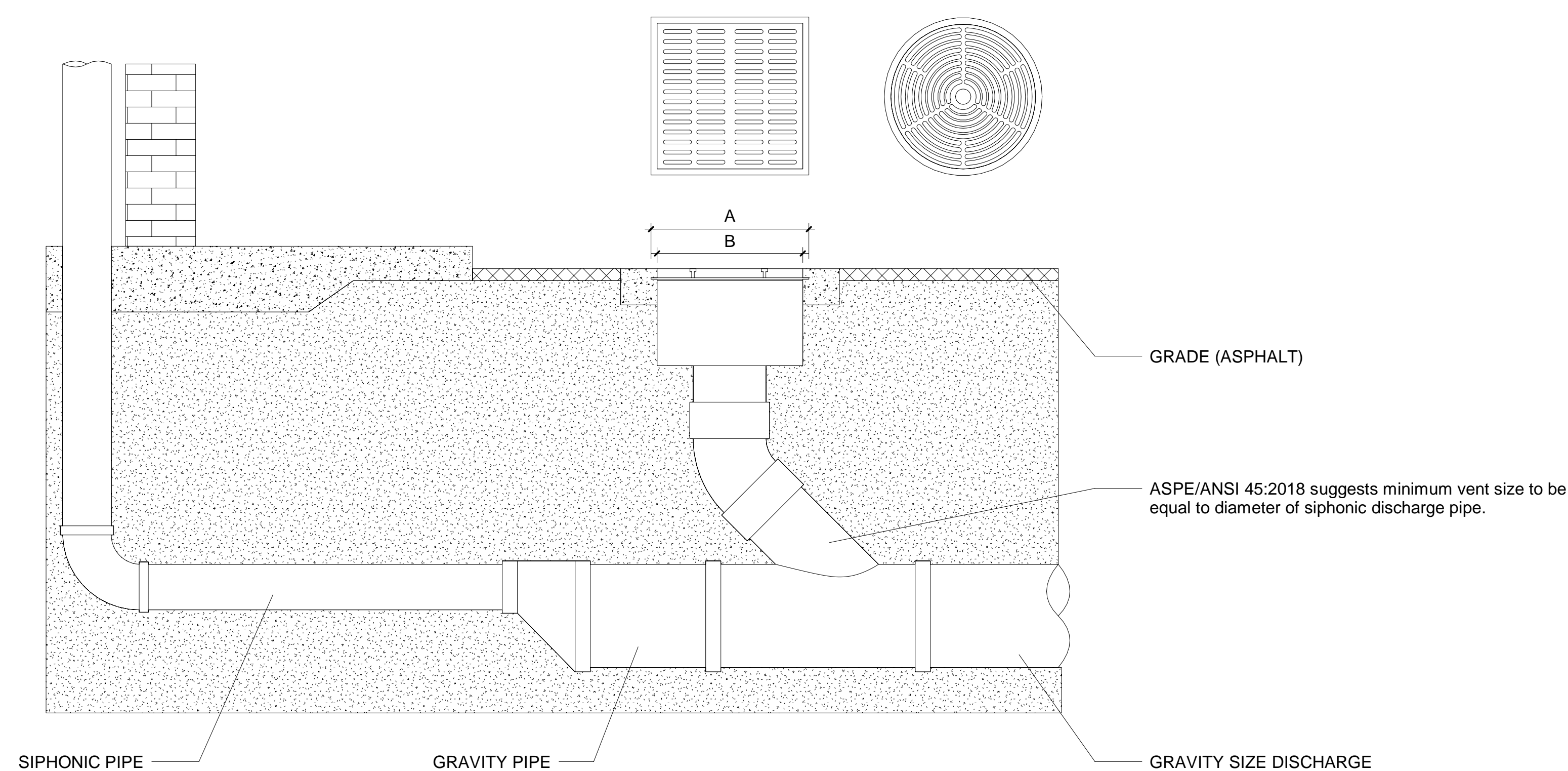

1 SIPHON BREAK IN HORIZONTAL
Scale: NTS

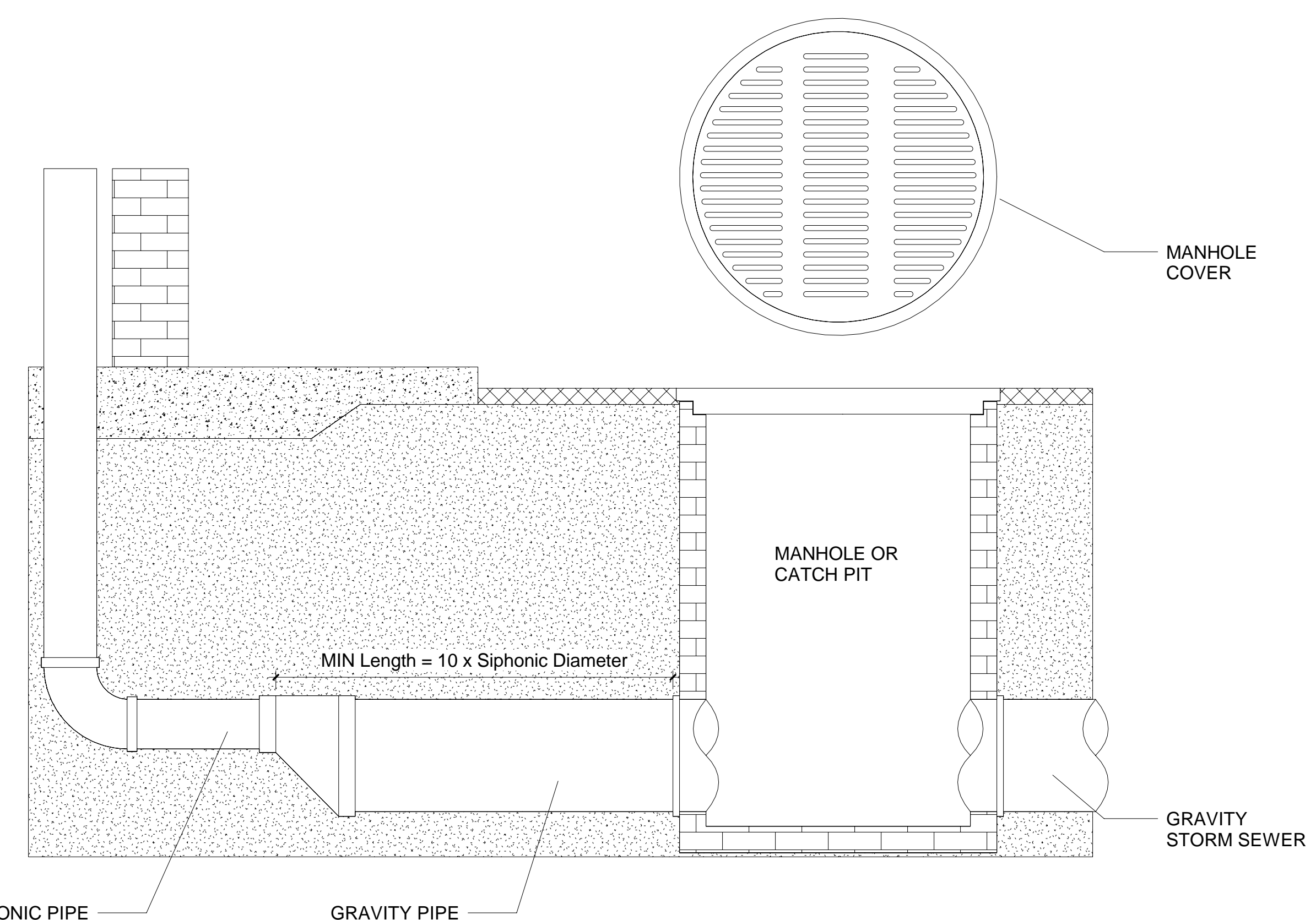

3 SIPHON BREAK TO MANHOLE
Scale: NTS

ASPE 45:

- 9.9.3 Flare out the discharge piping 10 or more pipe diameter prior to the vented manhole or sump. The resulting pipe diameter should be sufficient to return the system to open channel flow.

ASPE 45:

9.9.2 A vent pipe of a minimum diameter equivalent to the siphonic discharge pipe may be extended from the manhole structure and terminate in an area approved by the governing plumbing code.

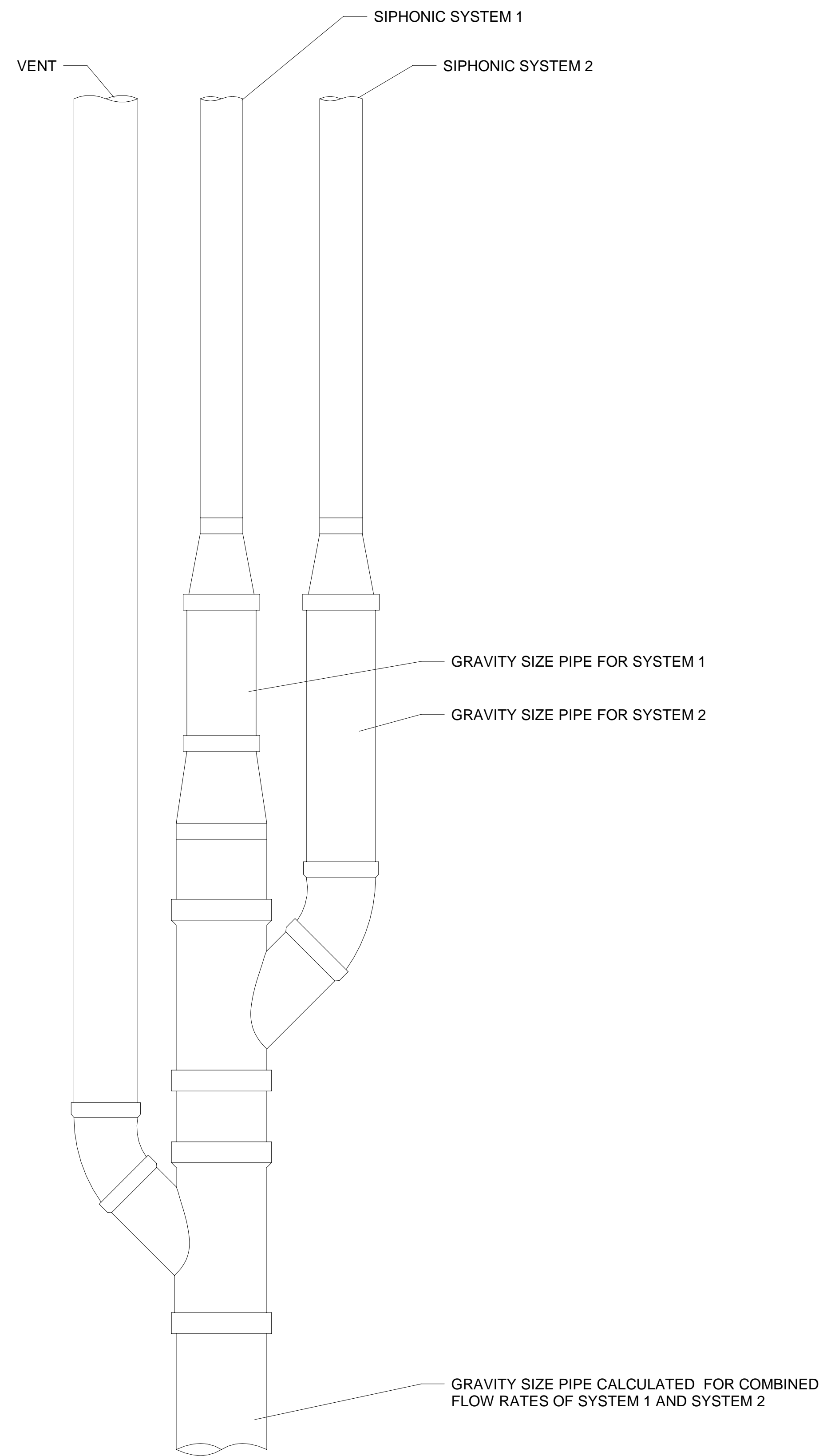

1 SIPHONIC + SIPHONIC COMBINATION
 Scale: NTS

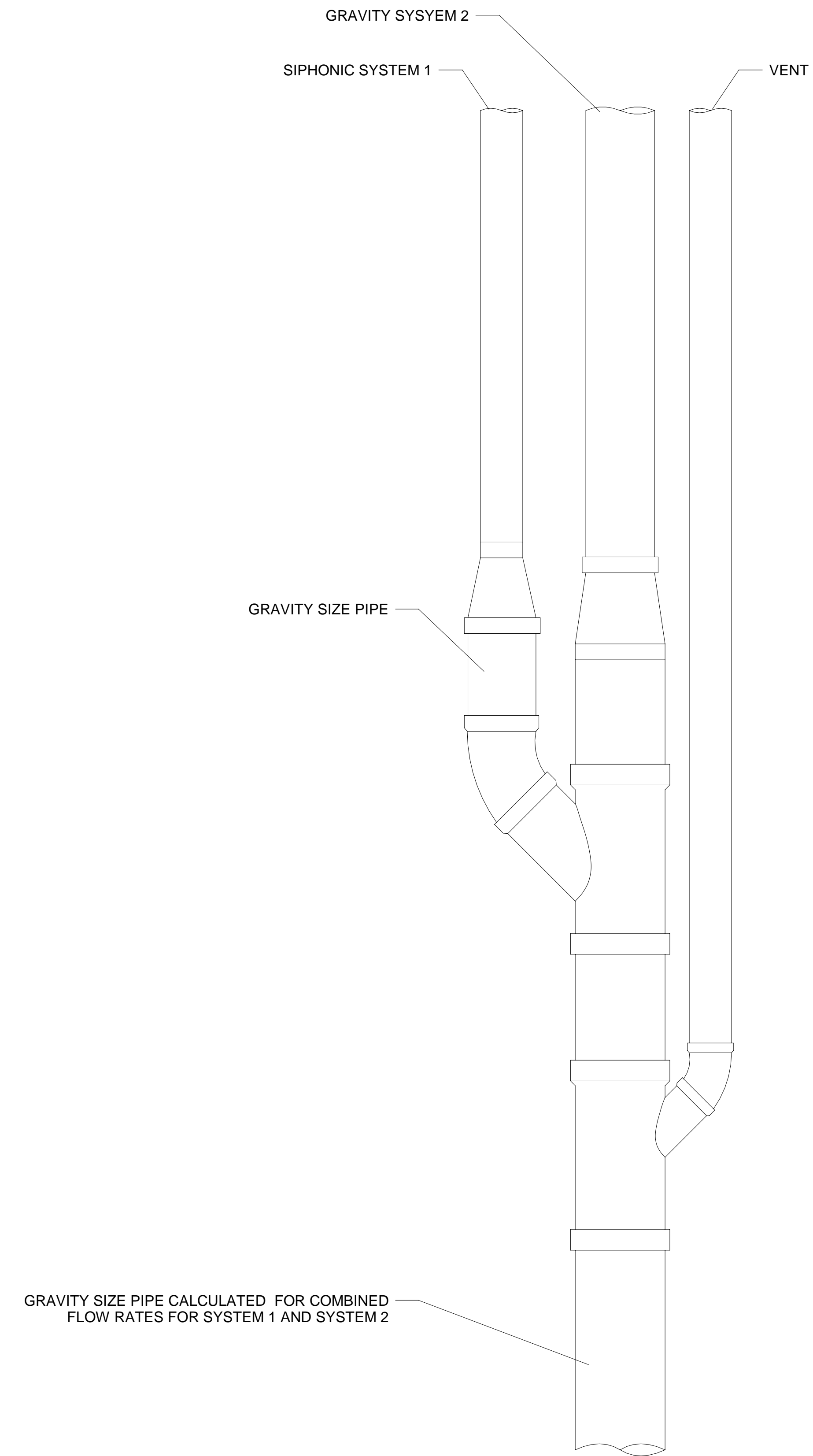

2 SIPHONIC + GRAVITY COMBINATION
 Scale: NTS

MIFAB Recommendation :
Increasing pipe diameter only does so much; create friction by adding change of directions on the gravity sized pipe where possible.

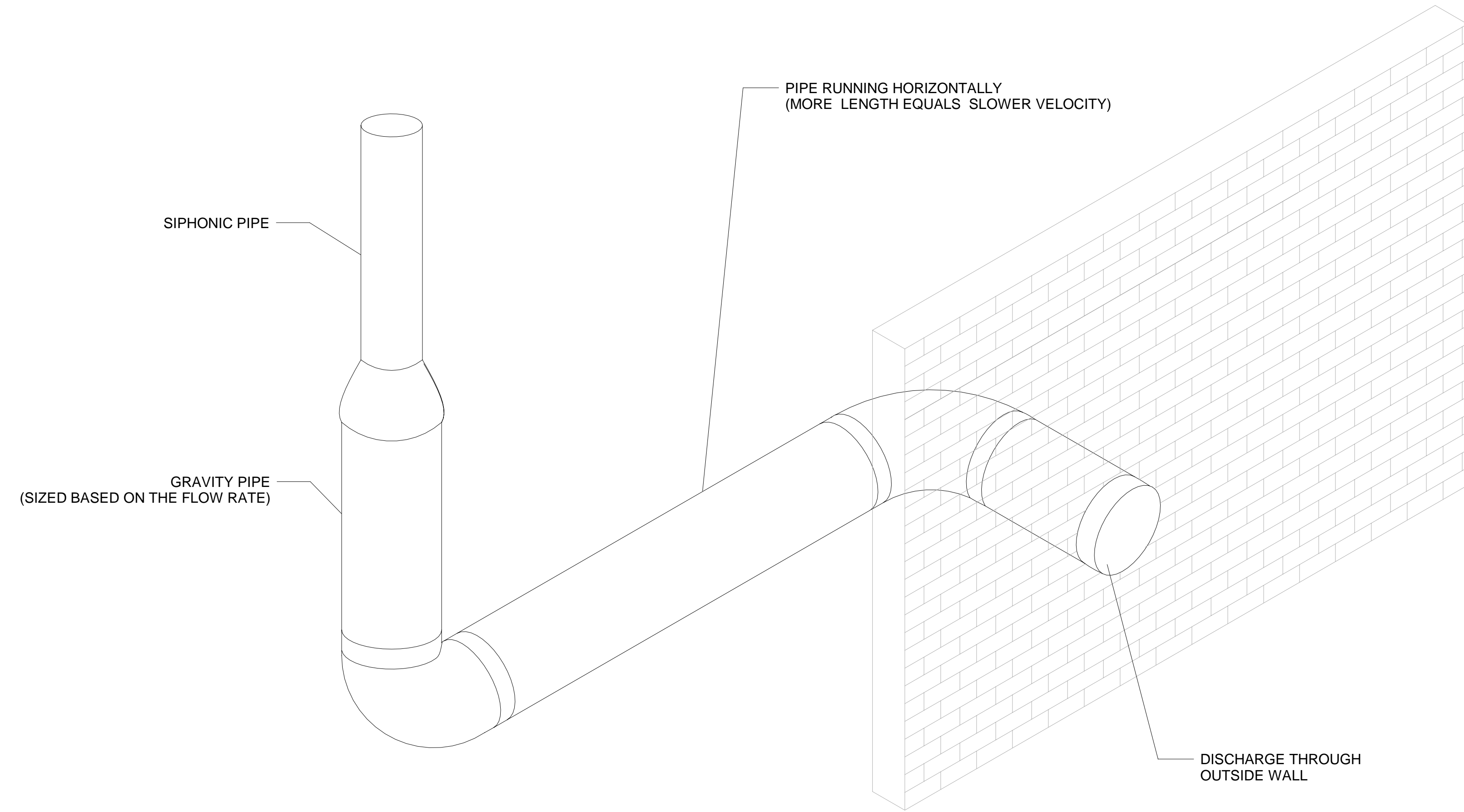

VIEW - 1

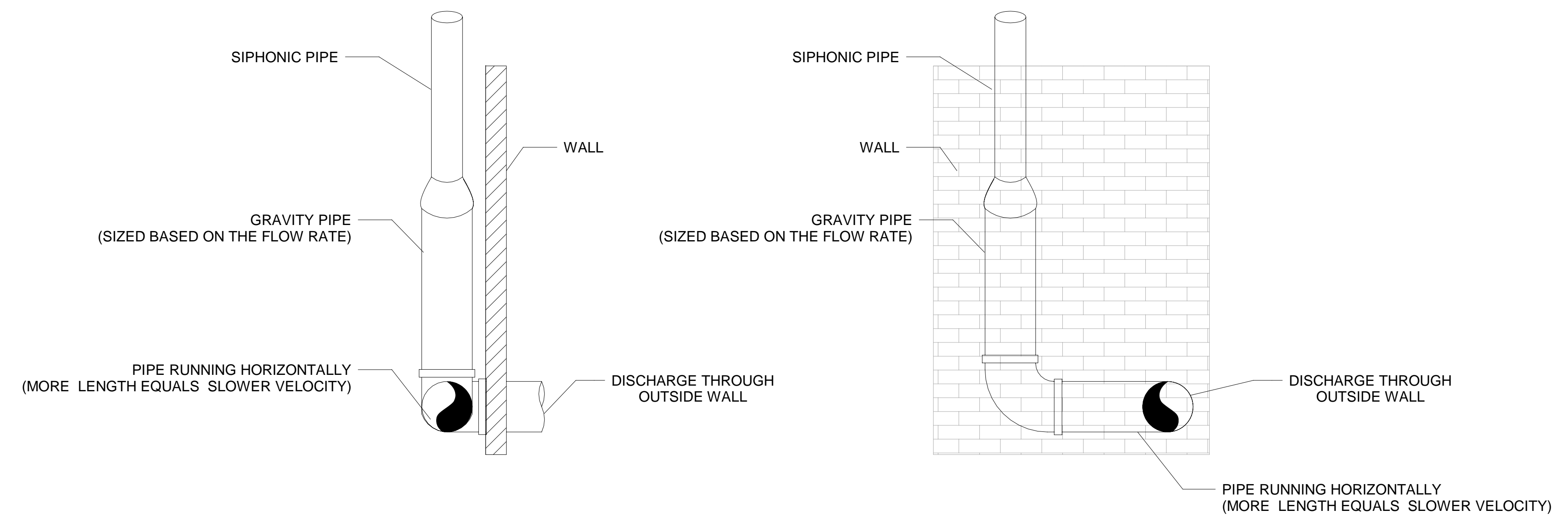

VIEW - 2

1 OVERFLOW DISCHARGE RECOMMENDATION - OFFSET TO THE SIDE OF WALL
 Scale: NTS

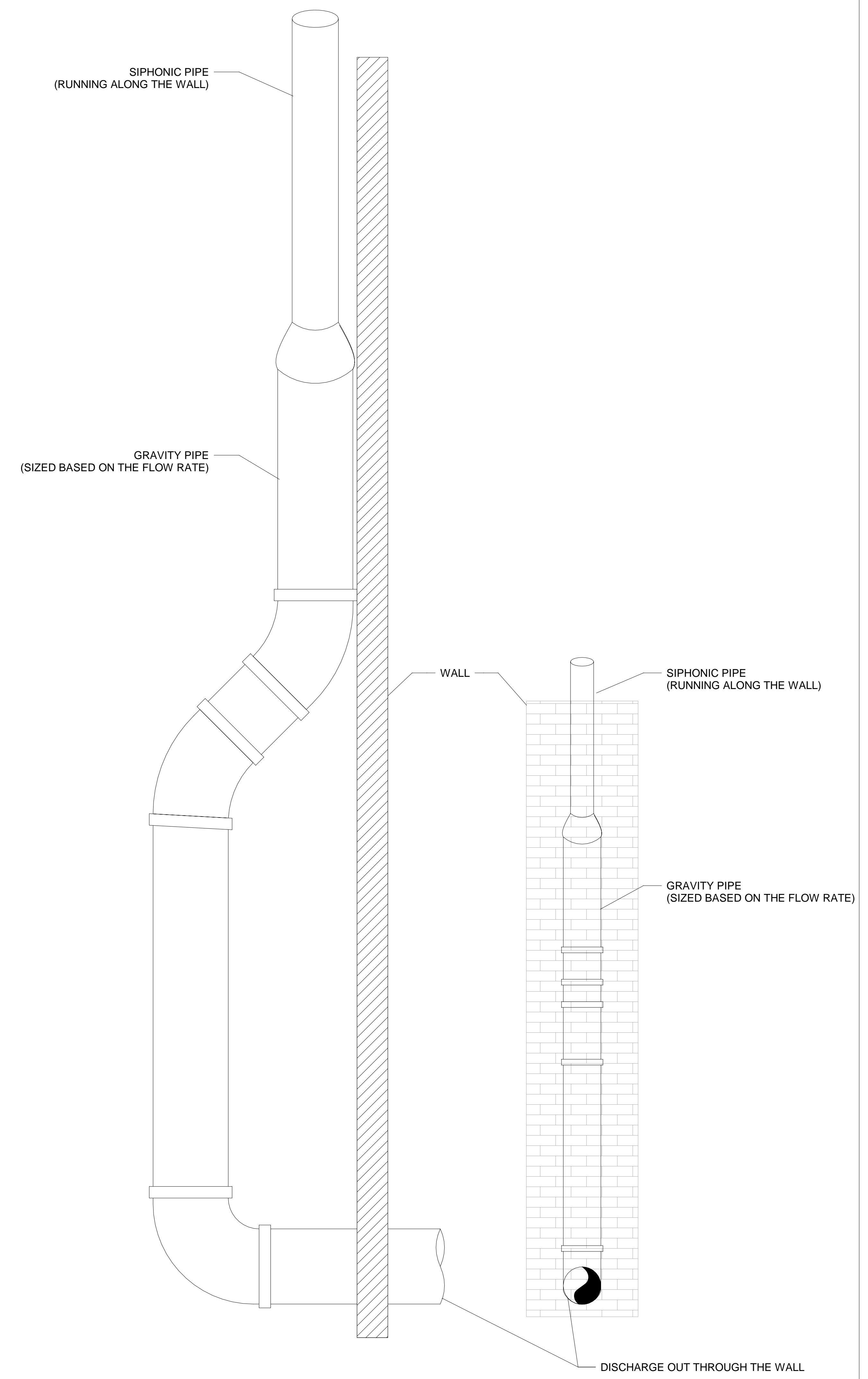

VIEW - 1

VIEW - 2

2 OVERFLOW DISCHARGE RECOMMENDATION - OFFSET AWAY FROM THE WALL
 Scale: NTS

ASPE 45:

9.3.3 PROVIDE APPROPRIATE THRUST RESTRAINTS AND ANCHORS IN THE PARTS OF THE SYSTEM EXPERIENCING THESE FORCES. RESTRAINTS AND ANCHORS MAY BE ATTACHED TO THE PIPE HANGER ONLY WHEN IS RIGIDLY ATTACHED TO THE PIPE.

9.3.4: IF THE DISTANCE FROM THE TOP OF A SUSPENDED PIPE TO THE POINT OF CONNECTION OF THE HANGER ROD IS GREATER THAN 18", LATERAL RESTRAINTS SHALL BE INSTALLED EVERY 30' AT EACH BRANCH TAKE-OFF AND AT EACH CHANGE OF THE DIRECTION.

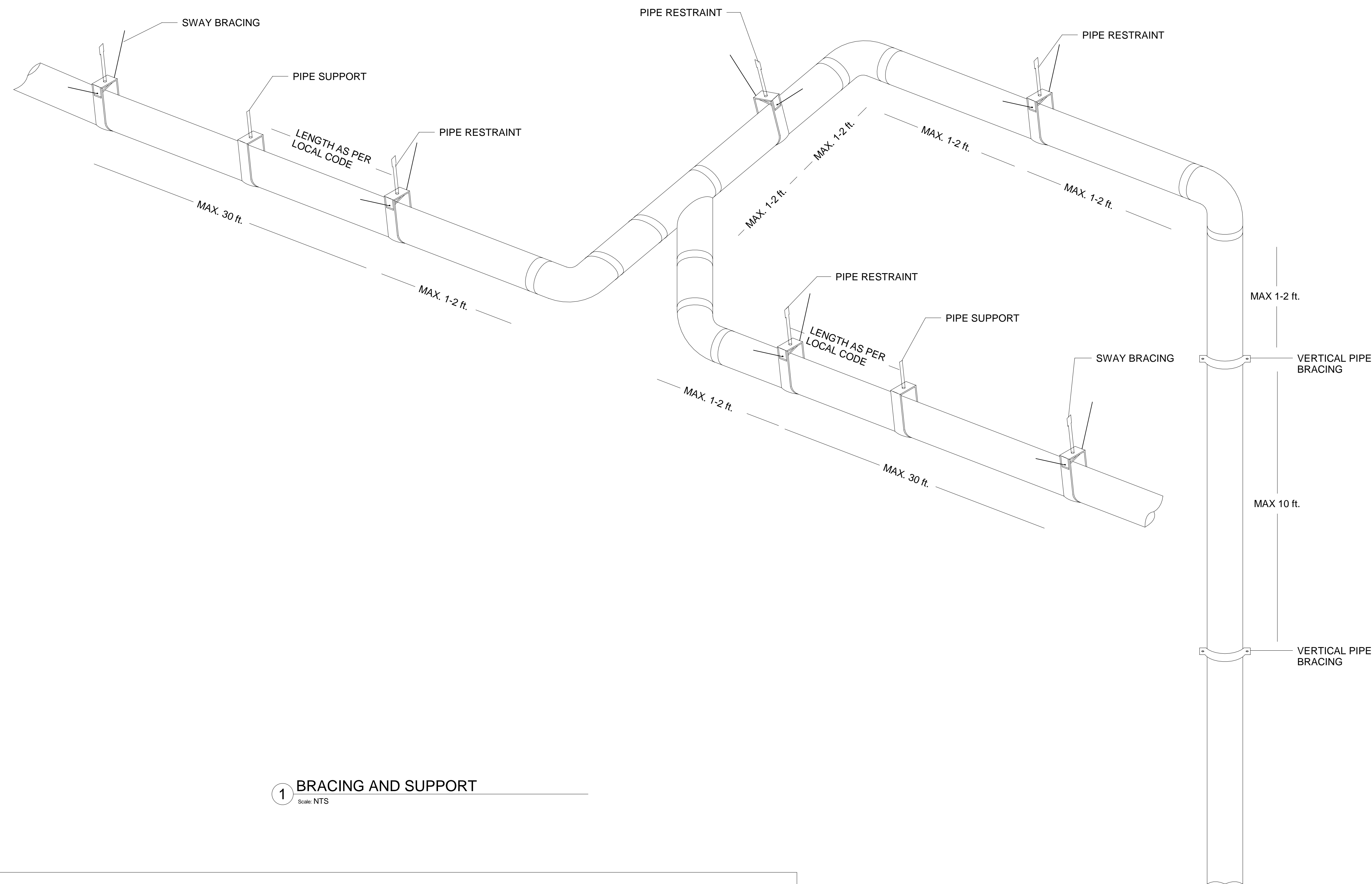

1 BRACING AND SUPPORT
 Scale: NTS

NEW REQUIREMENTS TO FOLLOW:

1. PIPE BRACING 1-2ft AWAY FROM EVERY CHANGE OF DIRECTION (i.e. A WYE HAS 3 BRACES).
2. SWAY BRACING EVERY 30ft. (IF PIPE GREATER THAN 18" BELOW CEILING).

STANDARD REQUIREMENTS(SAME AS GRAVIT) :

3. PIPE SUPPORT IN THE HORIZONTAL (FOLLOW CISPI OR PVC STANDARD).
4. PIPE BRACING IN THE VERTICAL EVERY 10ft.

IPC 2015 CODE

1107.1 GENERAL SIPHONIC ROOF DRAINS AND DRAINAGE SYSTEMS SHALL BE DESIGNED IN ACCORDANCE WITH ASME A112.6.9 AND ASPE 45.

UPC 2018 CODE

1106.2 SIPHONIC ROOF DRAINAGE SYSTEMS THE DESIGN OF A SIPHONIC ROOF DRAINAGE SYSTEM SHALL COMPLY WITH ASPE 45.

1106.3 SIPHONIC ROOF DRAINS SIPHONIC ROOF DRAINS SHALL COMPLY WITH ASME A112.6.9

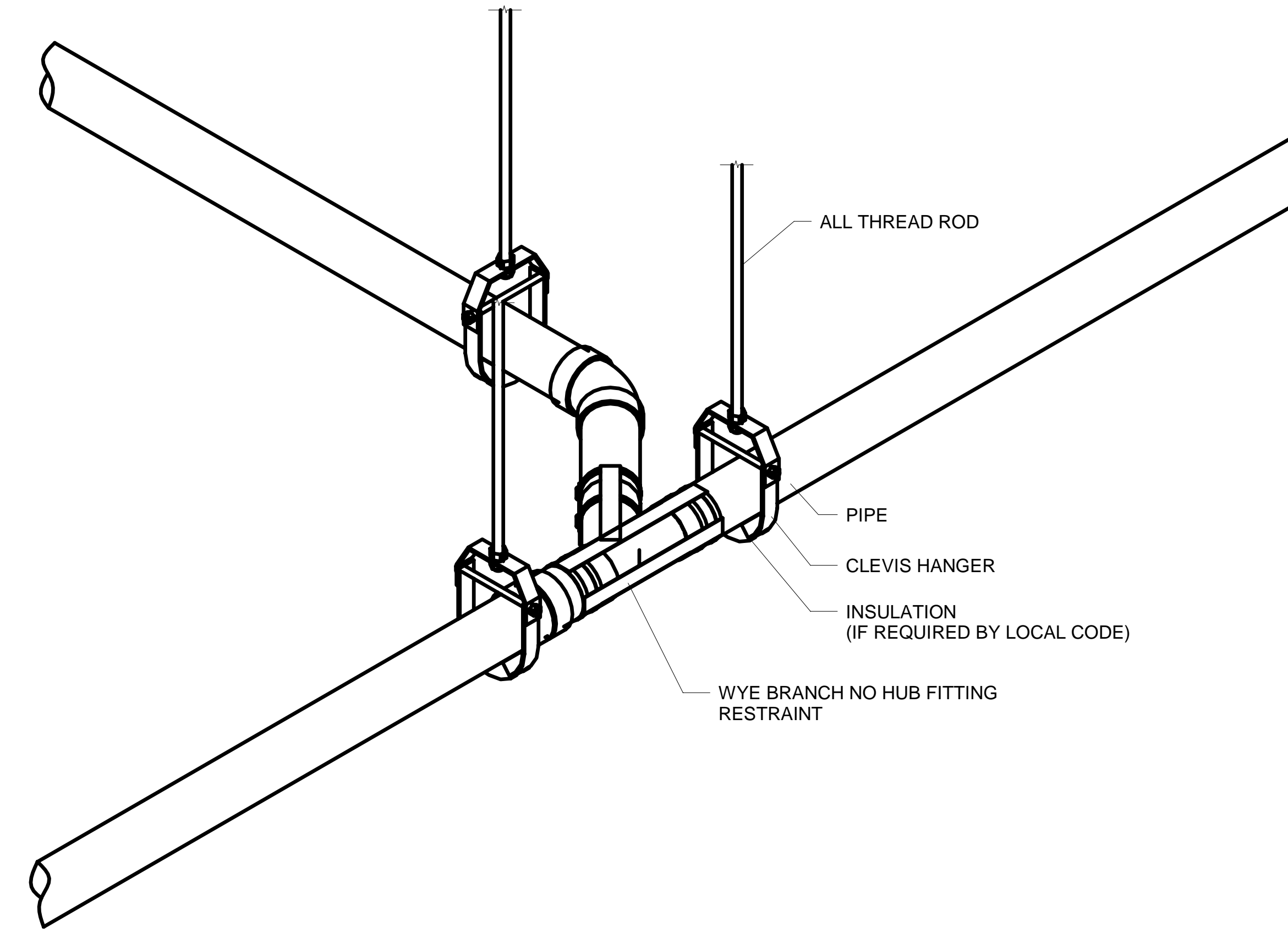
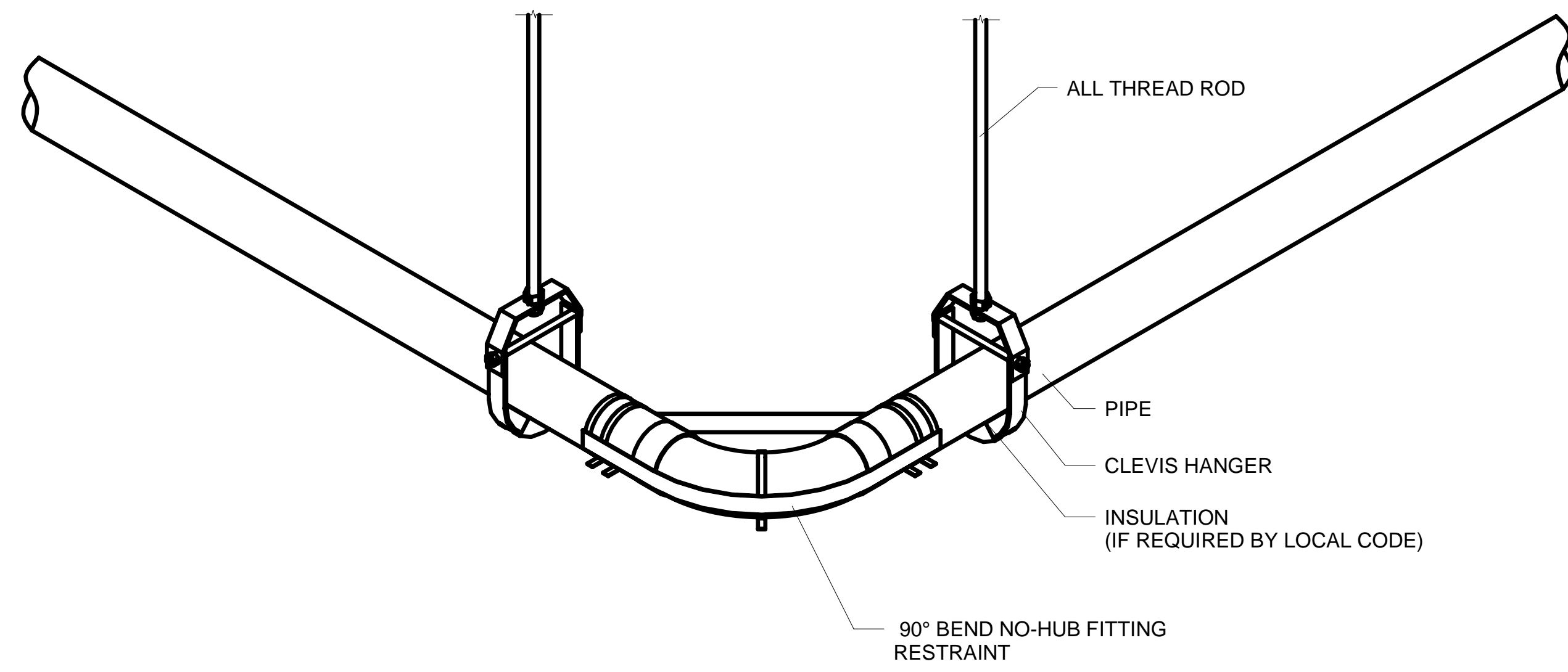

NOTES :

1. RESTRAIN SIPHONIC DRAIN LINES TO SATISFY THE REQUIREMENTS OF ASPE 45.
2. DRAIN LINES SHALL BE RESTRAINED AT EACH BRANCH TAKE-OFF, AND EACH CHANGE OF DIRECTION.
3. LATERAL SUPPORTS SHALL BE PROVIDED AT EACH DRAIN TAILPIECE AS CLOSE TO DRAIN CONNECTION AS POSSIBLE.

FITTING RESTRAINT

FITTING RESTRAINT

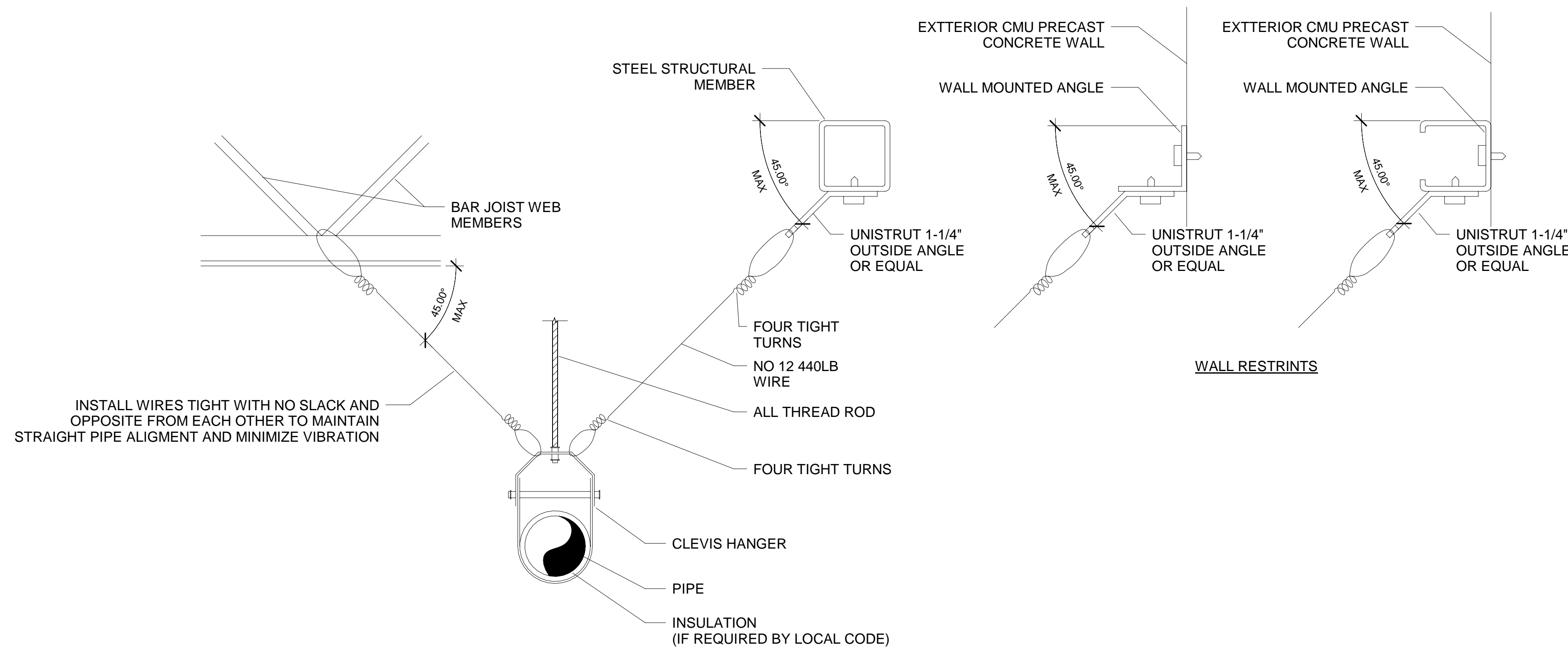

NOTES :

1. RESTRAIN SIPHONIC DRAIN LINES TO SATISFY THE REQUIREMENTS OF ASPE 45.
2. DRAIN LINES SHALL BE RESTRAINED AT INTERVALS NOT EXCEEDING 30 FT.
3. TWO OPPOSING LATERAL SUPPORTS SHALL BE PROVIDED.

PIPE RESTRAINT

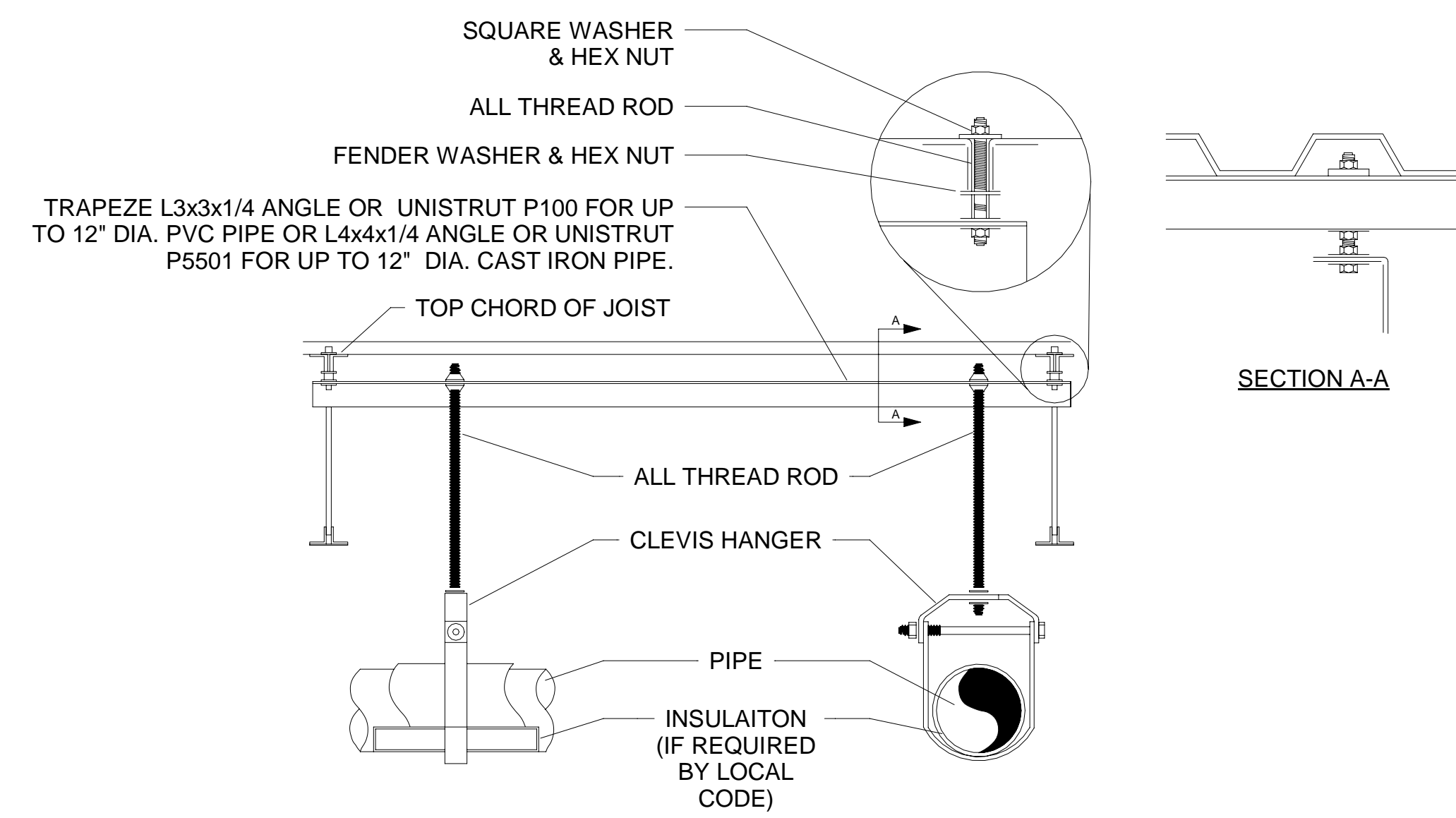

NOTE:

1. SPACE HANGERS AND SUPPORTS IN ACCORDANCE WITH SPECIFICATIONS.
2. DO NOT SUPPORT PIPING FROM BOTTOM CHORD OF BAR JOISTS.
3. DO NOT HANG 2 OR MORE 8 INCH OR LARGER PIPE BETWEEN THE SAME JOIST SPACE.
4. THE USE OF BEAM CLAMPS IS NOT PERMITTED.

PIPE SUPPORT

Fittings Approved For Siphonic Drainage

Bends should be:
- 90° (¼) Long Radius
- DWV swept 90° (¼)
- 45° (⅛)

All branches have to single be 45° Wye's
- Knuckle Bends are NOT permitted
- Double or combination branches are NOT permitted
- **Concentric and Eccentric reducers both allowed**

ASPE 45:

- 2.2.5 All changes in direction in the horizontal plane shall be sweep radius elbows or a combination of eighth-bend elbows or an eighth-bend elbow and lateral wye.
- 2.2.6 Change from vertical to horizontal shall be sweep radius elbows or a combination of eighth-bend elbows. If combinations of eight-bend elbows are used, they should be directly connected without a pipe section between them.

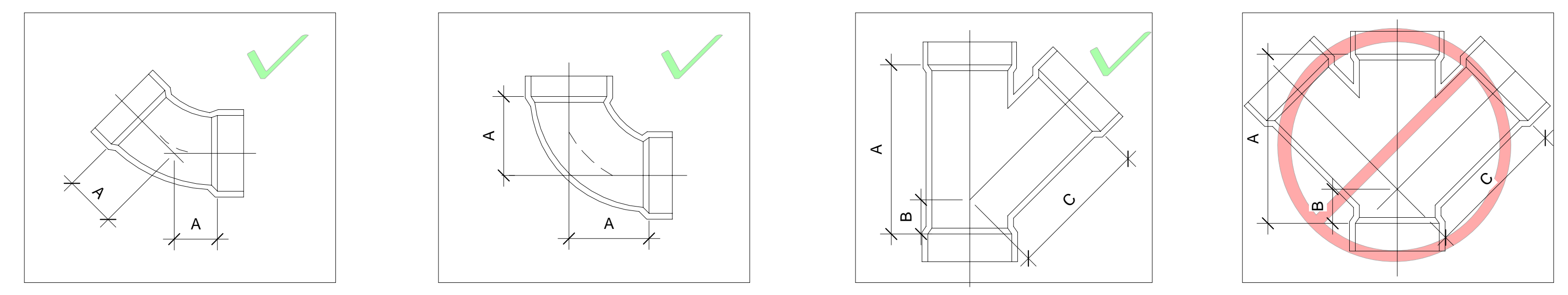

Cleanouts not required by ASPE 45 standard and are optional
Use spool style cleanout to eliminate air pocket if desired

ASPE 45:

- 9.5.2 Clean out fittings creating an air pocket or a discontinuity in pipe flow should be avoided wherever possible.
- 9.5.3 If cleanouts are to be included, they should be designed as a removable spool piece or fitting by means of an approved mechanical coupling.

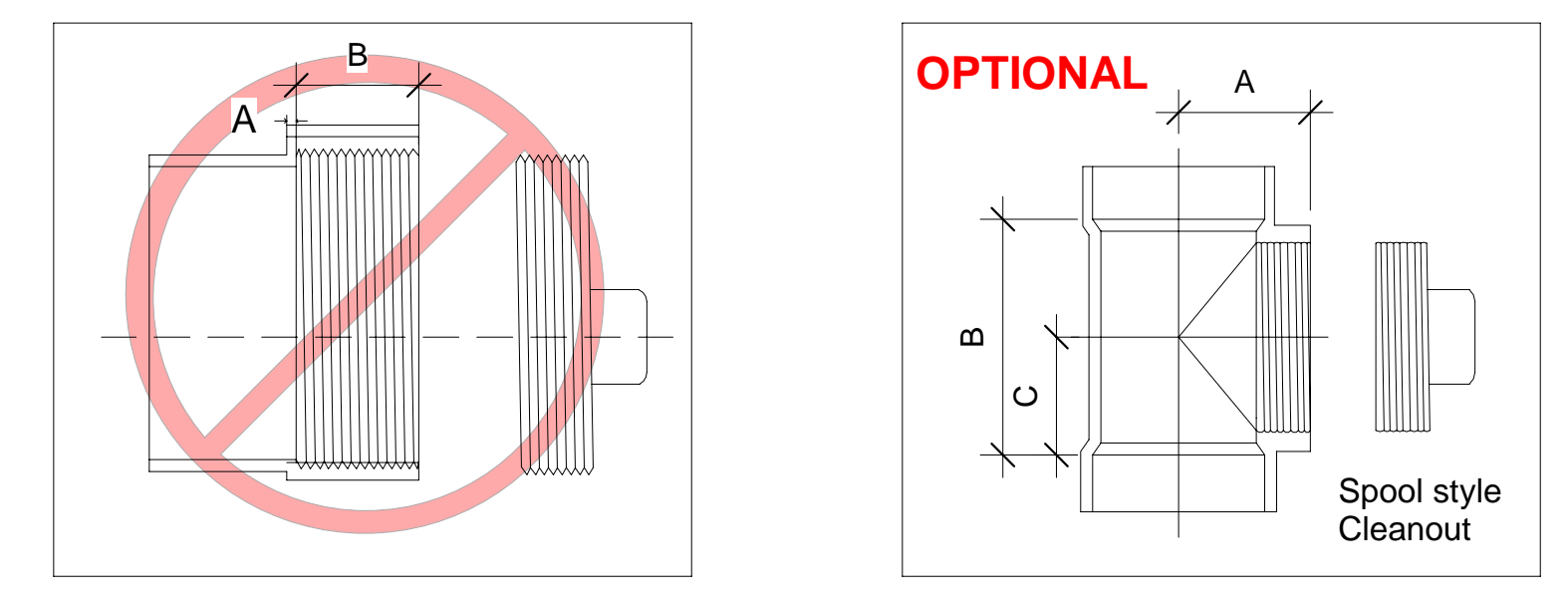

ASPE 45:

- 7.10.4 In general, use increasers only in the horizontal orientation to transition to a larger pipe diameter. Use reducers only in the vertical orientation to transition to a smaller pipe diameter.
- 9.6.2 When eccentric reducers are used, they shall be installed with the flat side oriented with the pipe crowns and the sloped side with the invert.
- 9.6.3 Eccentric reducers placed in the vertical just after an elbow turning down shall have the flat side oriented with the outside radius of the elbow.

Piping Rules for Siphonic Drainage

ASPE 45:

- 1.1.3 Local building and plumbing code requirements for pipe cleanouts, changes in direction, pitch of the piping and prohibitions for reductions in pipe size in the direction of fluid flow shall not apply to siphonic roof drainage design.
- 1.1.4 Pipe and drain sizing methodologies prescribed in locally adopted state plumbing codes shall not apply to the pipe sizing of siphonic roof drainage systems.

Horizontal Pipework: OKAY to increase pipe size; do NOT decrease pipe size

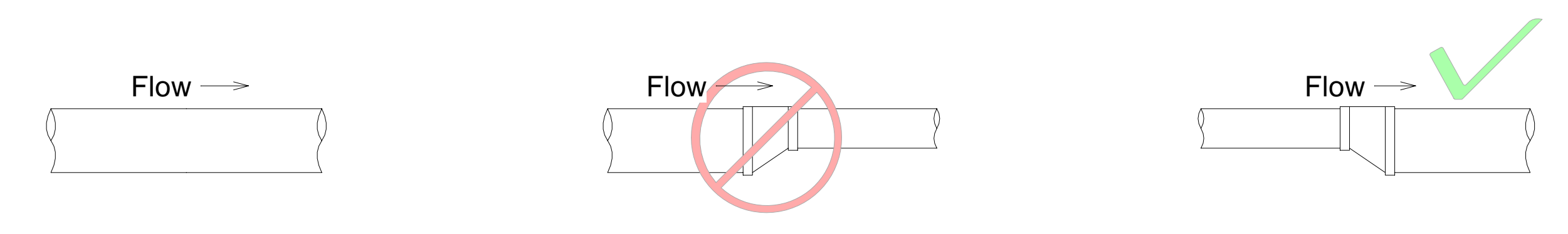

Vertical Pipework: OKAY to decrease pipe size; do NOT increase pipe size

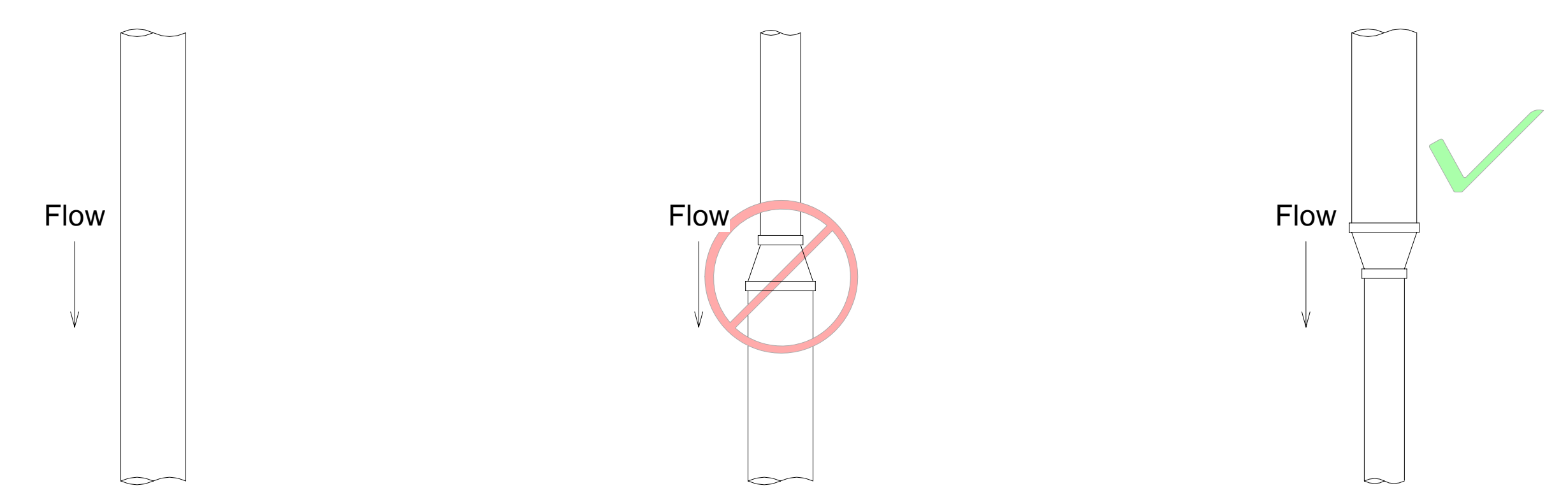

Tailpipe Design: Use only vertical/horizontal pipe

A bend creates turbulence forcing vertical to **PRIME**

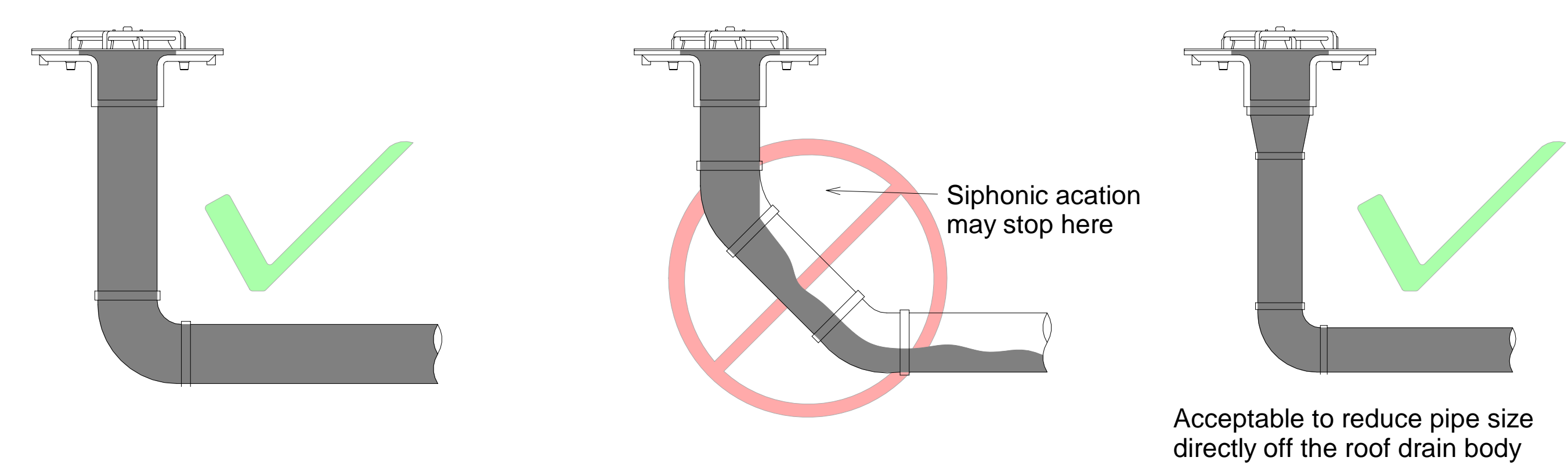

Priming and Four Flow Patterns of Siphonic Drainage			
Stage 1 : Gravity Flow	Stage 2 : Plug Flow	Stage 3 Bubble Flow	Stage 4 : Full-Bore Flow
Light Rainfall Approx. 0-10% of design	Moderate Rainfall Approx. 10-40% of design	Heavy Rainfall Approx. 40-70% of design	Intense Rainfall Approx. 70-100% of design
Gravity flow in pipework Air above water Water finds its way to the vertical and runs down the pipe.	Plug of water filling whole pipe at high velocities which achieves self-cleansing. Air pockets driven down pipework Tests have shown that self-cleansing can be achieved at as low as 10% to 15% of the design rainfall rate.	Water filling whole pipe Air bubbles in suspension carried at high velocity	No more air entry Air within pipe now fully purged

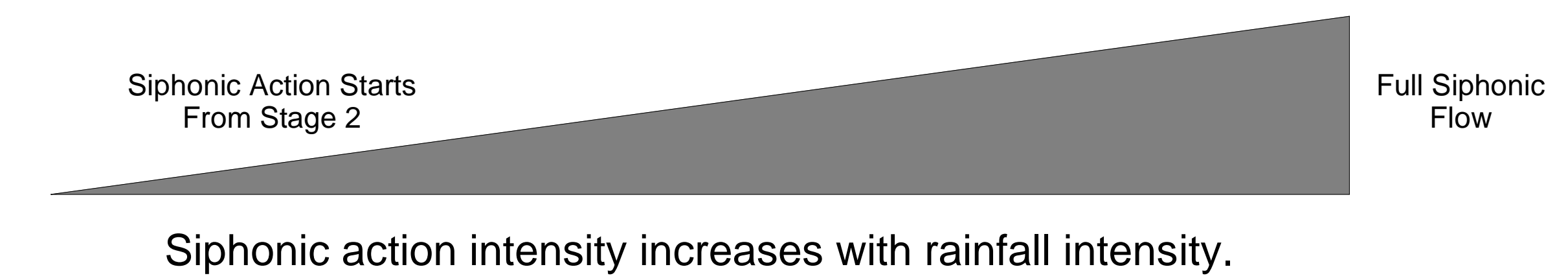

Step 1: SIPHONIC ROOF DRAIN Direct Cut MH-300, MH-400, MH-500, MH-600

FOR USE IN ENGINEERED SIPHONIC ROOF DRAINAGE SYSTEMS, FURNISHED STANDARD WITH EPOXY COATED CAST IRON BODY, MEMBRANE CLAMP DEVICE AND AIR BAFFLE/ INDUCER, 304 STAINLESS STEEL HARDWARE AND NO-HUB BOTTOM OUTLET.

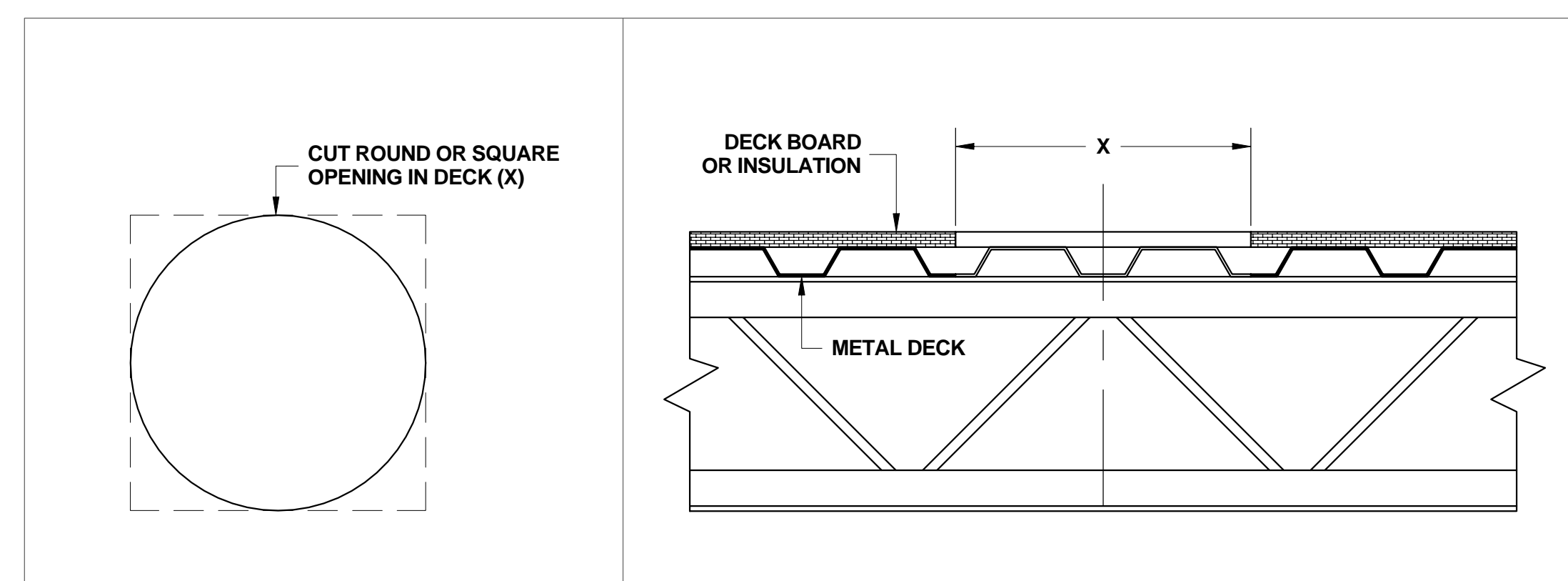

CATALOG NUMBER	PIPE SIZE	X (DECK OPENING)
MH-300	3 (75)	8 1/2 (216)
MH-400	4 (100)	13 (330)
MH-500	5 (125)	13 (330)
MH-600	6 (150)	16 (406)

MIFAB® Hydromax siphonic roof drains are compliant with ANSI/ASME A112.6.9 and are IAPMO Listed (file No. 6009).

- AT THE PREDETERMINED LOCATION LOCATE THE CENTER FOR THE DRAIN OPENING & SCRIBE TO 'X' DIMENSION
- VERIFY THAT THERE ARE NO OBSTRUCTIONS UNDER THE AREA WHERE THE DRAIN IS TO BE LOCATED.
- CHECK TO INSURE THAT THE LOCATION IS TO THE SYSTEM ENGINEERED PLANS. A SIPHONIC SYSTEM MUST BE LOCATED PRECISELY - DO NOT DEVIATE FROM PLANS.
- IF THE SPECIFIED LOCATION HAS INTERFERENCES OR IF A LOCATION CHANGE IS DESIRED, DO NOT PROCEED. CONSULT WITH THE ENGINEERING AUTHORITY RESPONSIBLE FOR THE DESIGN SO THE CHANGE CAN BE RECALCULATED.
- IF NO PROBLEMS EXISTS AT THE PREDETERMIND SITE, CUT A ROUND OR SQUARE OPENING IN THE DECK (X - DIMENSION)

Step 2: SIPHONIC ROOF DRAIN Installing Bearing Pan MH-300, MH-400, MH-500, MH-600

FOR USE IN ENGINEERED SIPHONIC ROOF DRAINAGE SYSTEMS, FURNISHED STANDARD WITH EPOXY COATED CAST IRON BODY, MEMBRANE CLAMP DEVICE AND AIR BAFFLE/ INDUCER, 304 STAINLESS STEEL HARDWARE AND NO-HUB BOTTOM OUTLET.

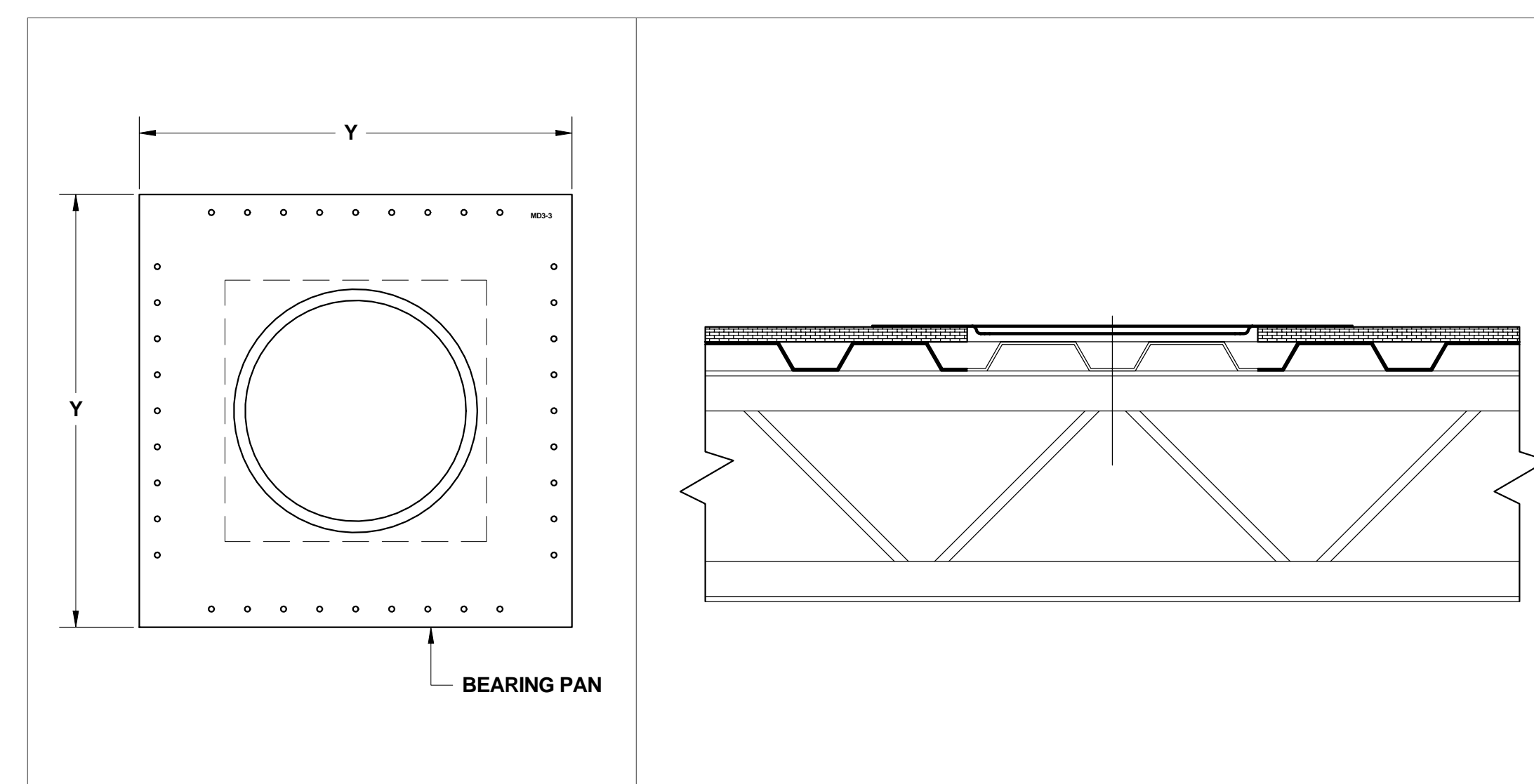

CATALOG NUMBER	PIPE SIZE	Y (DECK OPENING)
MH-300	3 (75)	24 (610)
MH-400	4 (100)	27 (686)
MH-500	5 (125)	27 (686)
MH-600	6 (150)	33 (838)

MIFAB® Hydromax siphonic roof drains are compliant with ANSI/ASME A112.6.9 and are IAPMO Listed (file No. 6009).

- (SKIP TO STEP 4 IF NO BEARING PAN USED)
- REFER TO DIRECT CUT INSTALL SHEET FOR HOLE DIMENSIONS.
 - INSTALL THE BEARING PAN (SUMP RECEIVER) INTO PRE CUT DECK OPENING.
 - THE BEARING PAN HAS PERIMETER HOLES FOR SECURING TO THE DECK. DECK SCREWS CAN BE USED TO SECURE THE BEARING PAN (IF DESIRED).

Step 3: SIPHONIC ROOF DRAIN Installing Drain Body MH-300, MH-400, MH-500, MH-600

FOR USE IN ENGINEERED SIPHONIC ROOF DRAINAGE SYSTEMS, FURNISHED STANDARD WITH EPOXY COATED CAST IRON BODY, MEMBRANE CLAMP DEVICE AND AIR BAFFLE/ INDUCER, 304 STAINLESS STEEL HARDWARE AND NO-HUB BOTTOM OUTLET.

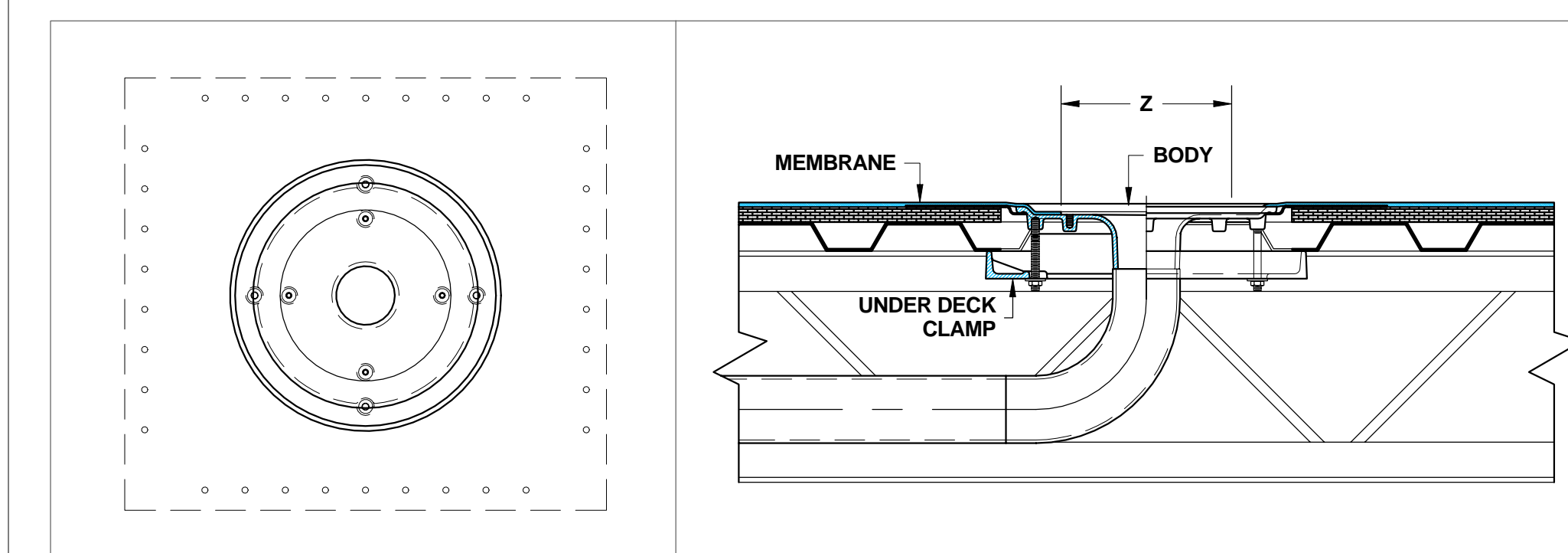

CATALOG NUMBER	PIPE SIZE	Z (DECK OPENING)
MH-300	3 (75)	8 1/2 (216)
MH-400	4 (100)	13 (330)
MH-500	5 (125)	13 (330)
MH-600	6 (150)	16 (406)

MIFAB® Hydromax siphonic roof drains are compliant with ANSI/ASME A112.6.9 and are IAPMO Listed (file No. 6009).

- INSTALL SIPHONIC DRAIN BODY INTO BEARING PAN RECESS.
- FROM UNDERSIDE, INSTALL UNDER DECK CLAMPS AND TIGHTEN SECURELY.
- INSTALLATION OF PIPE MAY THEN PROCEED. MAKE SURE TO FOLLOW PIPE ROUTES EXACTLY TO THE ENGINEERING PLANS FOR THE SYSTEM. NO DEVIATION IS ALLOWED AS THIS IS AN ENGINEERED SYSTEM. ANY MODIFICATION TO THE PIPING ARRANGEMENT MUST BE SUBMITTED TO THE ENGINEER FOR EVALUATION.
- FROM THE ROOF SIDE, THE WATERPROOF MEMBRANE CAN BE INSTALLED. APPLY THE MEMBRANE TO THE MANUFACTURERS RECOMMENDATIONS.
- CUT THE MEMBRANE IN A CIRCULAR PATTERN TO THE 'Z' DIMENSION IN THE CENTER OF THE DRAIN.

Step 4: SIPHONIC ROOF DRAIN Securing Membrane Clamp MH-300, MH-400, MH-500, MH-600

FOR USE IN ENGINEERED SIPHONIC ROOF DRAINAGE SYSTEMS, FURNISHED STANDARD WITH EPOXY COATED CAST IRON BODY, MEMBRANE CLAMP DEVICE AND AIR BAFFLE/ INDUCER, 304 STAINLESS STEEL HARDWARE AND NO-HUB BOTTOM OUTLET.

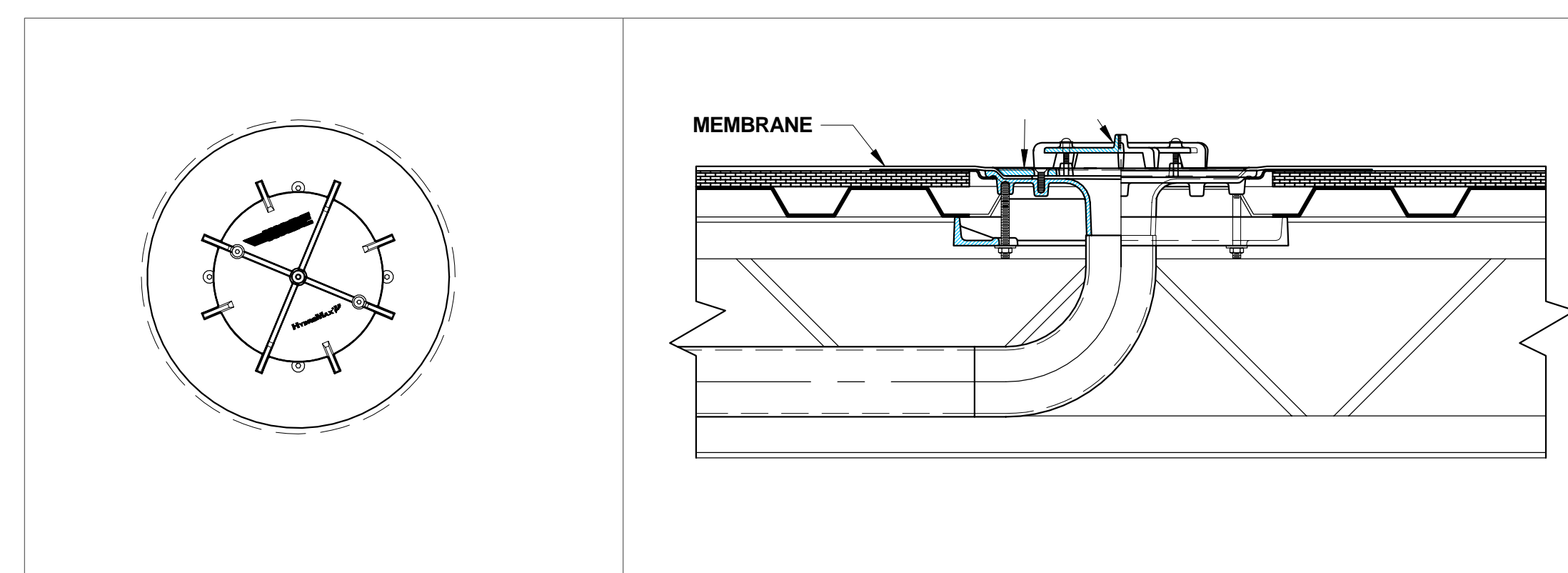

CATALOG NUMBER	PIPE SIZE
MH-300	3 (75)
MH-400	4 (100)
MH-500	5 (125)
MH-600	6 (150)

MIFAB® Hydromax siphonic roof drains are compliant with ANSI/ASME A112.6.9 and are IAPMO Listed (file No. 6009).

- (IF NO BEARING PAN USED) FROM UNDERSIDE, INSTALL UNDER DECK CLAMPS AND TIGHTEN SECURELY.
- FROM THE ROOF SIDE, THE WATERPROOF MEMBRANE CAN BE INSTALLED. APPLY THE MEMBRANE TO THE MANUFACTURERS RECOMMENDATIONS.
- INSTALL THE FLASHING RING WITH THE HARDWARE PROVIDED. INSURE THAT THE SCREWS ARE TIGHT.
- INSTALL THE INDUCER ON TOP OF THE FLASHING RING WITH THE HARDWARE PROVIDED. THE INDUCER SECURES TO THE FLASHING RING WITH (2) SCREWS.

Optional: SIPHONIC ROOF DRAIN Adding Debris Guard MH-300, MH-400, MH-500, MH-600

FOR USE IN ENGINEERED SIPHONIC ROOF DRAINAGE SYSTEMS, FURNISHED STANDARD WITH EPOXY COATED CAST IRON BODY, MEMBRANE CLAMP DEVICE AND AIR BAFFLE/ INDUCER, 304 STAINLESS STEEL HARDWARE AND NO-HUB BOTTOM OUTLET.

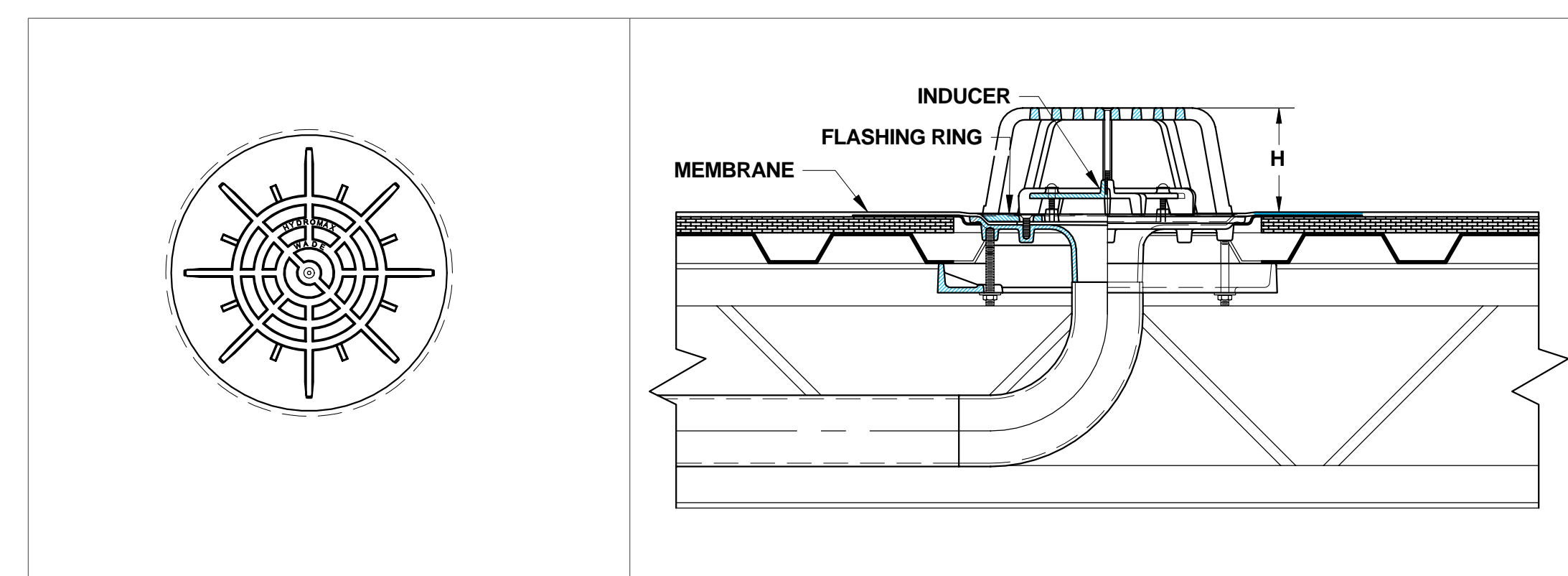

CATALOG NUMBER	PIPE SIZE	H
MH-300	3 (75)	5 (125)
MH-400	4 (100)	5 (125)
MH-500	5 (125)	5 (125)
MH-600	6 (150)	5 (125)

MIFAB® Hydromax Hydromax siphonic roof drains E with optional dome (debris guard) are compliant with IPC (International Plumbing Code) Section 1105.

MIFAB® Hydromax siphonic roof drains are compliant with ANSI/ASME A112.6.9 and are IAPMO Listed (file No. 6009).

- WITH THE INDUCER IN PLACE AND SECURED, INSTALL THE DOME (LEAFGUARD) ALIGNING THE LEGS BETWEEN THE INDUCER VANES. SECURE THE DOME WITH THE HARDWARE PROVIDED.

Direct Method: SIPHONIC ROOF DRAIN Screw from Underdeck MH-300, MH-400, MH-500, MH-600

FOR USE IN ENGINEERED SIPHONIC ROOF DRAINAGE SYSTEMS, FURNISHED STANDARD WITH EPOXY COATED CAST IRON BODY, MEMBRANE CLAMP DEVICE AND AIR BAFFLE/ INDUCER, 304 STAINLESS STEEL HARDWARE AND NO-HUB BOTTOM OUTLET.

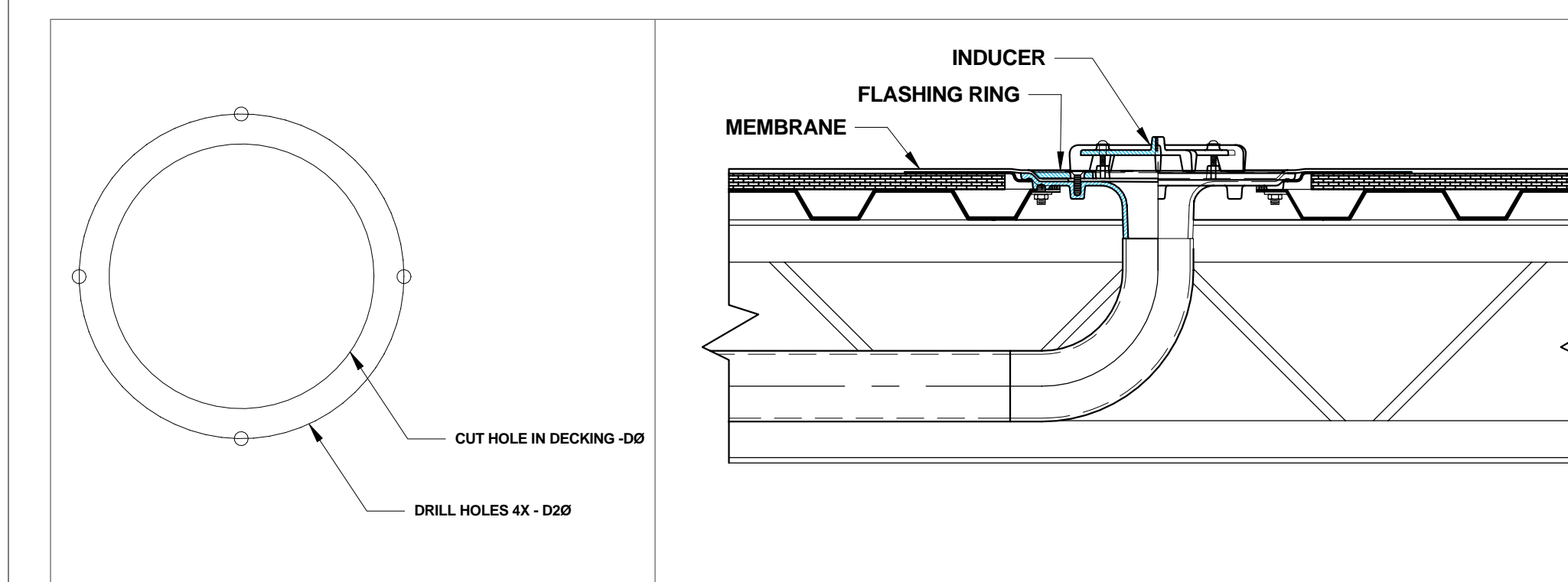

CATALOG NUMBER	PIPE SIZE	D Ø	D-2 Ø
MH-300	3 (75)	9"	11-1/16
MH-400	4 (100)	14"	17-3/32
MH-500	5 (125)	14"	17-3/32
MH-600	6 (150)	20"	20-11/16

MIFAB® Hydromax siphonic roof drains are compliant with ANSI/ASME A112.6.9 and are IAPMO Listed (file No. 6009).

- AT THE PREDETERMINED LOCATION LOCATE THE CENTER FOR THE DRAIN OPENING & SCRIBE TO 'D Ø' DIMENSION
- VERIFY THAT THERE ARE NO OBSTRUCTIONS UNDER THE AREA WHERE THE DRAIN IS TO BE LOCATED.
- CHECK TO INSURE THAT THE LOCATION IS TO THE SYSTEM ENGINEERED PLANS. A SIPHONIC SYSTEM MUST BE LOCATED PRECISELY - DO NOT DEVIATE FROM PLANS.
- IF THE SPECIFIED LOCATION HAS INTERFERENCES OR IF A LOCATION CHANGE IS DESIRED, DO NOT PROCEED. CONSULT WITH THE ENGINEERING AUTHORITY RESPONSIBLE FOR THE DESIGN SO THE CHANGE CAN BE RECALCULATED.
- DRILL HOLES AT THE 'D-2 Ø' DIMENSION THEN SECURELY TIGHTEN SCREWS FROM THE UNDERSIDE
- FROM THE ROOF SIDE, THE WATERPROOF MEMBRANE CAN BE INSTALLED. APPLY THE MEMBRANE TO THE MANUFACTURERS RECOMMENDATIONS.
- INSTALL THE FLASHING RING WITH THE HARDWARE PROVIDED. INSURE THAT THE SCREWS ARE TIGHT.
- INSTALL THE INDUCER ON TOP OF THE FLASHING RING WITH THE HARDWARE PROVIDED. THE INDUCER SECURES TO THE FLASHING RING WITH (2) SCREWS.